

### *FEATURES*

---

- Single full-duplex asynchronous channel
- 128-byte deep transmitter / receiver FIFO
- Fully software compatible with industry standard 16C550 type UARTs
- Readable FIFO levels
- System clock up to 60MHz
- Flexible clock prescaler from 1 to 31.875
- 9-bit data framing as well as 5,6,7 and 8
- Detection of bad data in the receiver FIFO
- Automated in-band flow control using programmable Xon/Xoff characters
- Transmitter and receiver can be disabled
- Low power CMOS
- 3.3V operation, 5V tolerant I/O
- Extended temperature range -40C to +105C
- Software compatible with OXCF950
- 16C950 mode for local bus applications
- Generic embedded driver compatibility mode
- Programmable by external Microwire™ EEPROM (EEPROM programmed via Oxford Semiconductor utilities).
- Extremely low power consumption by use of asynchronous UART core and power down (sleep) modes
- Range of packages -Ultra small 48 pin TQFP package or a 48 ball TFBGA.
- Supports all UART types 450 up to 950 (fully programmable)
- CF+ Compliant (Revision 1.4).
- 16-bit PC Card Compliant (PCMCIA Revision 7.1)
- 8 bit Local Bus interface included for PCMCIA applications
- 2 Multi-purpose I/O pins which can be configured as interrupt inputs

### *DESCRIPTION*

---

The OXCF950 rev B is a low cost asynchronous 16-bit PC card (henceforth referred to as PCMCIA) or Compact Flash (henceforth referred to as CF) UART (and Local Bus) device. Local Bus Selection is performed by use of a MODE pin. Note that Local Bus mode uses indirect addressing, which is only supported by PCMCIA.

The 3.3V technology has been specified to operate as low as 2.7 V to allow an in-line regulator to be used for mixed 3V/5V applications. All the I/Os are 5V tolerant with the exception of the clock/crystal oscillator input.

The EEPROM interface allows the programming of the Attribute Memory, UART and Local Configuration Registers during power up or hard/soft reset. This allows different card manufacturers to modify the information contained in the Attribute memory or UART/registers as required, for example PC-Card ID value.

A number of power-down modes are included to keep power consumption to a minimum. Such features include clock division (fully programmable) and sleep modes when a function of the OXCF950 rev B is not being used.

The OXCF950 rev B contains a single-channel ultra-high performance UART offering data rates up to 15Mbps and

128-deep transmitter and receiver FIFOs. Deep FIFOs reduce CPU overhead and allow utilisation of higher data rates.

It is software compatible with the widely used industry-standard 16C550 type devices and compatibles, as well as other OX16C95x family devices.

In addition to increased performance and FIFO size, the OXCF950 rev B also provides enhanced features including improved flow control. Automated software flow control using Xon/Xoff and automated hardware flow control using CTS#/RTS# and DSR#/DTR# prevent FIFO over-run. Flow control and interrupt thresholds are fully programmable and readable, enabling programmers to fine-tune the performance of their system. FIFO levels are readable to facilitate fast driver applications.

The addition of software reset enables recovery from unforeseen error conditions allowing drivers to restart gracefully. The OXCF950 rev B supports 9-bit data frames used in multi-drop industrial protocols. It also offers multiple external clock options for isochronous applications, e.g. ISDN, xDSL.

The OXCF950 rev B also incorporates a bridge to an 8 bit Local Bus in Local Bus Mode. It allows card developers to expand the capabilities of their products by adding peripherals to this bus. In addition, two user IO pins are included to enhance external device control. These IO pins can also be configured as interrupt inputs.

mode (pin or EEPROM selectable) allows the device to function in embedded systems where the generic device driver present assumes I/O occupancy of 8 byte addresses, without any additional components. The second mode (pin selectable) allows the device to act as a stand-alone 16C950 type part with the benefits over the 16C950 rev B of 5V tolerance, and packaging options where pin-compatibility with 550 type UARTs is not required.

The OXCF950 rev B fixes all known errata of the OXCF950 part. It also adds two new modes of operation. The first

### ***SUMMARY OF DIFFERENCES BETWEEN OXCF950 AND OXCF950 REV B***

---

The OXCF950 rev B has been designed to be as compatible as possible with the rev A part. A designer considering switching to the new device should be aware of the following –

- Power supply. The new part has a supply voltage range from 2.7V to 3.6V. The original part had a supply voltage range from 3.15V to 5.25V. A new design requiring operation at both 3.3V and 5V will require an in-line low voltage-drop regulator.
- Pin compatible (other than supply voltage constraints).
- Software compatible – all the modes of the original CF950 are available in the rev B device.
- All I/Os are now 5V tolerant, with the exception of the Crystal oscillator input.
- The crystal oscillator circuit is only suitable for frequencies up to 20 MHz. For operation above this frequency, an external clock source is required.
- A new 'generic' mode has been added allowing generic drivers to access the UART without needing external circuitry to adjust the address ranges. This mode (8 byte I/O space) can be selected either by pin control or through the EEPROM. Access to configuration registers is still possible via a software paging technique.
- A stand-alone 16C950 type mode has been added (pin selectable) to allow the device to be used where pin-compatibility with 16C550 type devices is not required.
- All known errata in the original OXCF950 have been fixed.
- The device is now characterised for an extended operating temperature range of –40C to +105C.
- The CF950 rev B is additionally available in a 48 TFBGA package.
- The input clock frequency may be restricted by the CF950 rev B environment. Where an external EEPROM is being used, the maximum clock frequency of the external EEPROM multiplied by 64 will give a input clock frequency limit. For an external EEPROM powered off 5V with a maximum frequency of 1MHz, this sets no limits. An EEPROM powered off 2.7V may typically have a maximum frequency of 250 kHz, which would restrict the CF950 rev B input frequency to 16 MHz.

Software can identify the difference between an OXCF950 and an OXCF950 rev B by reading the UART REV register (see 6.11.7)

For the original OXCF950 this reads 0x06, for the OXCF950 rev B this reads 0x08.

Throughout this document, the OXCF950 rev B will henceforth simply be referred to as the OXCF950.

*CONTENTS*

FEATURES .....	1
DESCRIPTION .....	1
SUMMARY OF DIFFERENCES BETWEEN OXCF950 AND OXCF950 REV B.....	2
CONTENTS.....	3
REVISION HISTORY.....	5
1 BLOCK DIAGRAM .....	6
2 PIN INFORMATION .....	7
3 PIN DESCRIPTIONS.....	8
4 CONFIGURATION & OPERATION .....	11
4.1 MODE SELECTION .....	11
4.1.1 GENERIC MODE .....	11
4.1.2 16C950 MODE.....	11
4.1.3 NORMAL/LOCAL BUS MODES.....	11
4.2 PCMCIA/CF OPERATION .....	11
5 PCMCIA / CF TARGET CONTROLLER.....	13
5.1 OPERATION .....	13
5.2 CONFIGURATION SPACE (CARD INFORMATION STRUCTURE).....	13
5.2.1 LOCAL BUS MODE SPACE MAP .....	13
5.2.2 NORMAL MODE SPACE MAP .....	14
5.3 ACCESS TO IO FUNCTION .....	14
5.3.1 ACCESS TO INTERNAL UART .....	14
5.3.2 ACCESS TO LOCAL BUS .....	14
5.3.3 ACCESSING LOCAL CONFIGURATION REGISTERS .....	15
5.4 CF / PCMCIA INTERRUPT .....	19
5.4.1 INTERRUPT GENERATION.....	19
5.4.2 INTERRUPT SOURCES.....	19
5.5 CF/PCMCIA FUNCTION CONFIGURATION REGISTERS .....	20
5.5.1 CONFIGURATION OPTIONS REGISTER 'COR' (OFFSET 0XF8).....	20
5.5.2 CONFIGURATION STATUS REGISTER 'CSR' (OFFSET 0XFA).....	21
5.5.3 PIN REPLACEMENT REGISTER 'PRR' (OFFSET 0XFC).....	22
5.5.4 SOCKET AND COPY REGISTER 'SCR' (OFFSET 0XFE).....	23
5.6 CARD INFORMATION STRUCTURE .....	23
5.6.1 LOCAL BUS MODE .....	23
5.6.2 NORMAL MODE .....	25
5.6.3 GENERIC NORMAL MODE.....	27
6 INTERNAL 950 UART .....	30
6.1 MODE SELECTION .....	30
6.1.1 450 MODE.....	30
6.1.2 550 MODE.....	30
6.1.3 750 MODE.....	30
6.1.4 650 MODE.....	30
6.1.5 950 MODE.....	30
6.2 REGISTER DESCRIPTION TABLES .....	32
6.3 RESET CONFIGURATION .....	35
6.3.1 HOST RESET .....	35
6.3.2 SOFTWARE RESET .....	35

6.4	TRANSMITTER & RECEIVER FIFOS .....	35
6.4.1	FIFO CONTROL REGISTER 'FCR' .....	36
6.5	LINE CONTROL & STATUS.....	37
6.5.1	FALSE START BIT DETECTION.....	37
6.5.2	LINE CONTROL REGISTER 'LCR'.....	37
6.5.3	LINE STATUS REGISTER 'LSR' .....	37
6.6	INTERRUPTS & SLEEP MODE.....	39
6.6.1	INTERRUPT ENABLE REGISTER 'IER'.....	39
6.6.2	INTERRUPT STATUS REGISTER 'ISR'.....	40
6.6.3	INTERRUPT DESCRIPTION .....	40
6.6.4	SLEEP MODE.....	41
6.7	MODEM INTERFACE .....	41
6.7.1	MODEM CONTROL REGISTER 'MCR' .....	41
6.7.2	MODEM STATUS REGISTER 'MSR' .....	42
6.8	OTHER STANDARD REGISTERS .....	42
6.8.1	DIVISOR LATCH REGISTERS 'DLL & DLM' .....	42
6.8.2	SCRATCH PAD REGISTER 'SPR' .....	42
6.9	AUTOMATIC FLOW CONTROL.....	42
6.9.1	ENHANCED FEATURES REGISTER 'EFR' .....	42
6.9.2	SPECIAL CHARACTER DETECTION .....	43
6.9.3	AUTOMATIC IN-BAND FLOW CONTROL .....	44
6.9.4	AUTOMATIC OUT-OF-BAND FLOW CONTROL .....	44
6.10	BAUD RATE GENERATION.....	44
6.10.1	GENERAL OPERATION .....	44
6.10.2	CLOCK PRESCALER REGISTER 'CPR' .....	45
6.10.3	TIMES CLOCK REGISTER 'TCR' .....	45
6.10.4	INPUT CLOCK OPTIONS .....	46
6.10.5	TTL CLOCK MODULE .....	46
6.10.6	EXTERNAL 1X CLOCK MODE.....	47
6.10.7	CRYSTAL OSCILLATOR CIRCUIT .....	47
6.11	ADDITIONAL FEATURES .....	47
6.11.1	ADDITIONAL STATUS REGISTER 'ASR' .....	47
6.11.2	FIFO FILL LEVELS 'TFL & RFL' .....	48
6.11.3	ADDITIONAL CONTROL REGISTER 'ACR' .....	48
6.11.4	TRANSMITTER TRIGGER LEVEL 'TTL' .....	49
6.11.5	RECEIVER INTERRUPT. TRIGGER LEVEL 'RTL' .....	49
6.11.6	FLOW CONTROL LEVELS 'FCL & FCH' .....	49
6.11.7	DEVICE IDENTIFICATION REGISTERS.....	50
6.11.8	CLOCK SELECT REGISTER 'CKS' .....	50
6.11.9	NINE-BIT MODE REGISTER 'NMR' .....	50
6.11.10	MODEM DISABLE MASK 'MDM' .....	51
6.11.11	READABLE FCR 'RFC' .....	51
6.11.12	GOOD-DATA STATUS REGISTER 'GDS' .....	52
6.11.13	DMA STATUS REGISTER 'DMS' .....	52
6.11.14	PORT INDEX REGISTER 'PIX' .....	52
6.11.15	CLOCK ALTERATION REGISTER 'CKA' .....	52
6.11.16	MISC DATA REGISTER .....	52
7	SERIAL EEPROM SPECIFICATION .....	53
7.1	EEPROM DATA ORGANISATION .....	53
7.2	ZONE 0: HEADER .....	53
7.3	ZONE 1: CARD INFORMATION STRUCTURE.....	54
7.4	ZONE 2: LOCAL REGISTER CONFIGURATION .....	54
7.5	ZONE 3: FUNCTION ACCESS (UART).....	55
8	OPERATING CONDITIONS.....	56
9	DC ELECTRICAL CHARACTERISTICS .....	57

9.1 3.0V TO 3.6V OPERATION..... 57

9.2 2.7V – 3.6V OPERATION..... 58

10 TIMING WAVEFORMS / AC CHARACTERISTICS ..... 59

10.1 MEMORY ACCESS..... 59

10.2 I/O ACCESS..... 60

11 PACKAGE INFORMATION..... 62

12 ORDERING INFORMATION ..... 64

NOTES ..... 65

CONTACT DETAILS..... 66

DISCLAIMER ..... 66

*REVISION HISTORY*

---

REV	DATE	REASON FOR CHANGE / SUMMARY OF CHANGE
Jul 2005	05/07/2005	Revision for additional order code

# 1 BLOCK DIAGRAM

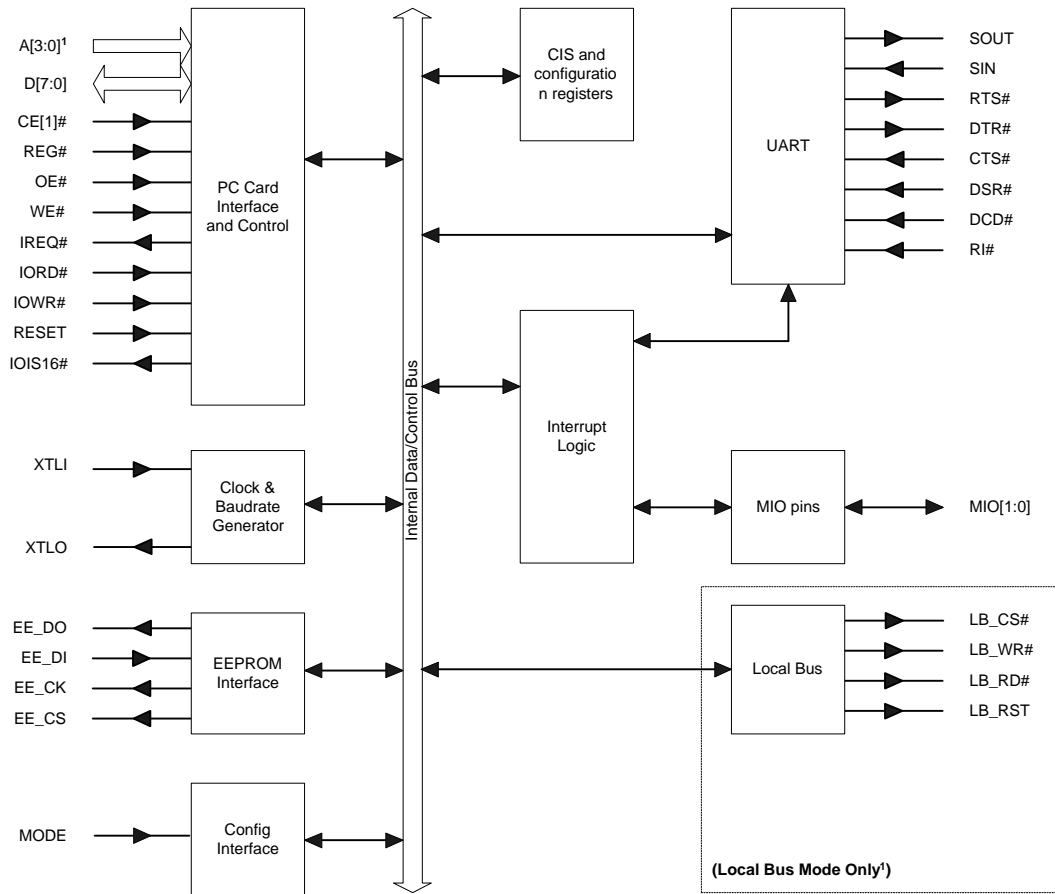

Figure 1: Block Diagram

## 2 PIN INFORMATION

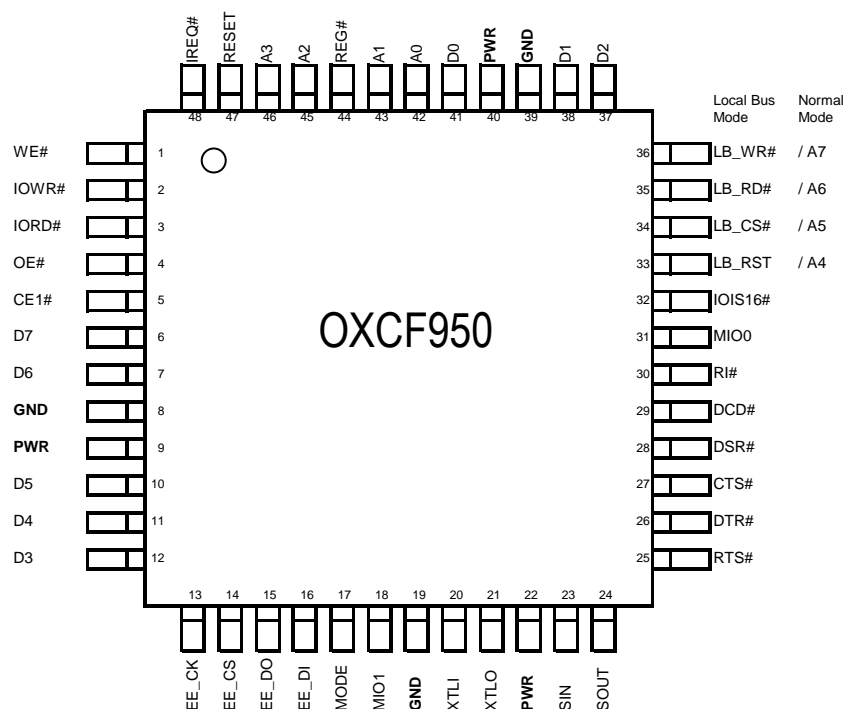

Figure 2: Pin Information (TQFP)

	1	2	3	4	5	6
A	READY# IREQ#	A2	A1	D0	GND	D2
B	WE#	RESET	A0	VDD	D1	LBWR# TXRDY# A7
C	IORD#	IOWR#	REG#	LBRD# RXRDY# A6	WP IOIS16# INT	LBCS# OUT1# A5
D	CE1#	OE#	GND	A3	RI#	MIO0
E	D6	D7	GND	LBRST OUT2# A4	DSR#	DCD#
F	D5	VDD	D4	XTLO	DTR#	CTS#
G	D3	EE_CS	EE_DI	MIO1	SIN	RTS#
H	EE_CK	EE_DO	MODE	XTLI	VDD	SOUT

Figure 3: TFBGA Ball Information

### 3 PIN DESCRIPTIONS

TOFP Pin Number (TFBGA ball)	Dir <sup>1</sup>	Name	Description
<b>CF/PCMCIA Interface and Control</b>			
46, 45, 43, 42 (D4, A2, A3, B3)	I	A[3:0]	PCMCIA/CF address bus, bits [3:0]
6, 7, 10, 11, 12, 37, 38, 41 (E2, E1, F1, F3, G1, A6, B5, A4)	I/O	D[7:0]	PCMCIA/CF data bi-directional bus.
44 (C3)	IU	REG#	Register select and I/O enable
5 (D1)	IU	CE[1]#	Active low card enable
4 (D2)	I	OE#	Active low memory read enable
1 (B1)	I	WE#	Active-low write enable used for strobing Memory Write data (Attribute memory).
3 (C1)	IU	IORD#	Active-low I/O read enable
2 (C2)	IU	IOWR#	Active-low I/O write enable
32 (C5)	O	WP	Write protect (in Memory only mode)
	O	IOIS16#	Data is 16 bit (in IO and Memory mode)
	O	INT	C950 Mode:Active-high interrupt request
47 (B2)	IU	RESET	PCMCIA/CF Reset
48 (A1)	O	READY#	Device ready (in Memory only mode)
		IREQ#	Active-low Interrupt request (in C950, IO and Memory mode).
<b>UART / Local Bus Function</b>			
24 (H6)	O	SOUT	UART serial data output.
		IrDA_Out	UART IrDA data output when MCR[6] is set in enhanced mode.
23 (G5)	I	SIN	UART serial data input.
		IrDA_In	UART IrDA data input when IrDA mode is enabled (see above).
29 (E6)	I	DCD#	Active-low modem data-carrier-detect input.
26 (F5)	O	DTR#	Active-low modem data-terminal-ready output. If automated DTR# flow control is enabled, the DTR# pin is asserted and de-asserted if the receiver FIFO reaches or falls below the programmed thresholds, respectively.
		485_En	In RS485 half-duplex mode, the DTR# pin may be programmed to reflect the state of the transmitter empty bit to automatically control the direction of the RS485 transceiver buffer (see register ACR[4:3]).
		Tx_Clk_Out	Transmitter 1x clock (baud rate generator output). For isochronous applications, the 1x (or Nx) transmitter clock may be asserted on the DTR# pin (see register CKS[5:4]).
25 (G6)	O	RTS#	Active-low modem request-to-send output. If automated RTS# flow control is enabled, the RTS# pin is de-asserted and reasserted whenever the receiver FIFO reaches or falls below the programmed thresholds, respectively.
27 (F6)	I	CTS#	Active-low modem clear-to-send input. If automated CTS# flow control is enabled, upon de-assertion of the CTS# pin,



			the transmitter will complete the current character and enter the idle mode until the CTS# pin is reasserted. Note: flow control characters are transmitted regardless of the state of the CTS# pin.
28 (E5)	I	DSR#	Active-low modem data-set-ready input. If automated DSR# flow control is enabled, upon de-assertion of the DSR# pin, the transmitter will complete the current character and enter the idle mode until the DSR# pin is reasserted. Note: flow control characters are transmitted regardless of the state of the DSR# pin
		Rx_Clk_In	External receiver clock for isochronous applications. The Rx_Clk_In is selected when register CKS[1:0] = '01'
30 (D5)	I	RI#	Active-low modem Ring-indicator input
		Tx_Clk_In	External transmitter clock. This clock can be used by the transmitter (and indirectly by the receiver) when register CKS[6] = '1'.
21 (F4)	O	XTLO	Crystal oscillator output
20 (H4)	I	XTLI	Crystal oscillator input or external clock pin. Frequency 1.8MHz -> 60MHz. For 1.8 to 20 MHz, a crystal may be used. Above this range, an external clock source is required.
34 (C6)	O O I	LBCS# OUT1# A[5]	Local Bus Mode : Active low local bus Chip select C950 Mode: Active low OUT1 Normal Mode : Address bit 5
35 (C4)	O O I	LBRD# <sup>2</sup> RXRDY# A[6]	Local Bus Mode : Active-low local bus read enable C950 Mode:Active low RXRDY Normal Mode : Address bit 6
36 (B6)	O O I	LBWR# TXRDY# A[7]	Local Bus Mode : Active-low local bus write enable C950 Mode:Active low TXRDY Normal Mode : Address bit 7
33 (E4)	O O I	LBRST <sup>2</sup> OUT2# A[4]	Local Bus Mode : Active high local bus Reset C950 Mode:Active low OUT2 Normal Mode : Address bit 4
<b>EEPROM</b>			
13 (H1)	O	EE_CK	EEPROM clock. In normal operation the frequency of this is XTLI input clock / 64. The clock is only active during configuration following reset.
14 (G2)	O	EE_CS	EEPROM active-high Chip Select.
16 (G3)	I	EE_DI	EEPROM data in. This pin should be pulled up using 1-10k resistor if an EEPROM is used, or pulled up/down depending upon required stand-alone mode..
15 (H2)	O	EE_DO	EEPROM data out.
<b>Miscellaneous Pins</b>			
18, 31 (G4, D6)	I/O	MIO[1:0]	User defined IO pins. Note: that if enabled, MIO[1:0] can be used as an interrupt inputs.
17 (H3)	I	MODE	Local Bus mode select. Note Local Bus mode requires indirect addressing, which is only supported by the PCMCIA specification '0' = Normal Mode (CF/PCMCIA compatible) '1' = Local Bus Mode (PCMCIA compatible)
<b>Power and Ground<sup>2</sup></b>			
39, 19, 8 (A5, E3, D3)	G	GND	Ground (0 Volts). The GND pins should be tied to ground

40, 22, 9 (B4, H5, F2)	V	VDD	Power supply. The VDD pins should be tied to 3.3 Volts
---------------------------	---	-----	--

Table 1: Pin Descriptions

Note 1: Direction key:

I	Input		
IU	Input with internal pull-up		
ID	Input with external pull-down		
O	Output	G	Ground
I/O	Bi-directional	V	3.3V power

## 4 CONFIGURATION & OPERATION

### 4.1 Mode Selection

The OXCF950 has four default modes of operation, as shown in the table below.

MODE pin	EE_DI pin	Operation
0	0	'Generic' Normal mode with 3 address bits decoded for I/O
1	0	16C950 mode (standard local bus type UART)
0	'1' or to external EEPROM	'Normal' mode with 4 address bits decoded for I/O
1	'1' or to external EEPROM	'Local Bus' mode with 4 address bits decoded for I/O

Table 2: Default Modes of Operation

#### 4.1.1 Generic Mode

Generic Mode is compatible with PCMCIA and CF host systems. It is the same as 'Normal' mode, except that when I/O accesses take place, only the bottom 3 bits of the address range are decoded. Similarly the Card Information Structure indicates an I/O range of 8 locations. This mode allows generic drivers to locate the UART on a default 8-byte boundary. In this mode access to the configuration registers is performed via paging. Generic mode address decoding can also be selected by EEPROM configuration.

#### 4.1.2 16C950 Mode

This mode is provided for non PCMCIA/CF applications. In this mode all the PCMCIA/CF decoding, CIS and EEPROM sections of the design are bypassed and the CF950 acts as a local-bus style device. To implement this mode - REG#, EE\_DI should be tied to GND, OE#, WE#, MODE should be tied to VDD. The user can use A3 to access configuration registers to allow control of MIO pins and the clock divider. For most applications, however, A3, MIO1 and MIO0 should also be tied to GND.

CE1#, IORD#, IOW# and A[2..0] then become the local bus chip-select and read, write, address access controls. IREQ# becomes an active-high interrupt output, and IOIS16# becomes an active-low interrupt output.

#### 4.1.3 Normal/Local Bus Modes

These modes are identical to the previous CF950 modes of operation. They are suitable for PCMCIA/CF host systems.

### 4.2 PCMCIA/CF Operation

PCMCIA and CF host systems allow for hot insertion of cards.

Once a card has been inserted into a host system, the host system will configure it. The PCMCIA standard defines two card detect pins, that allow the host to be notified when a card is inserted or removed.

By default the device will power up in either Normal or Local Bus mode, depending on the mode pin (and the EE\_DI pin for 'Generic' mode). The difference between these two modes is given in the following table. Note that the Local Bus mode is not suitable for CF systems.

Normal Mode (MODE=0)	Local Bus Mode (MODE=1)
Address bus is 8 bits wide.	Address bus is 4 bits wide.
Indirect access is not used.	Indirect access is used.
No external local bus.	External local bus supported.

Table 3: Differences between Normal & Local Bus Mode

The host system will wait for the READY# signal to be active before reading the Card Information Structure, given in attribute memory within the device. By reading this tuple information, the host system is able to identify the device type and the necessary resources requested by the device.

The host system will then load the device-driver software according to this information and will configure the IO, memory and interrupt resources. After determining that the device is a memory and IO type device the host will enable it's IO mode by writing to the device's Configuration Options Register in attribute memory space. Device drivers can then access the functions at the assigned addresses.

A set of local configuration registers have been provided that can be used to control the device's characteristics (such as interrupt handling) and report internal functional status. These registers can be accessed in IO space, utilising the same IO space as the local bus (Local Bus mode only) and are situated above the UART registers. These local registers can be set up by device drivers or from the optional EEPROM. In generic mode, the

configuration registers overlay the UART registers and are selected by paging.

The EEPROM can also be used to redefine the reset values of all register areas to tailor the device to the end users requirements if the default values do not meet the specific requirements of the manufacturer. This re-programming of the device can also be performed for the CIS area, allowing the manufacturer to modify resources required, or Manufacturer ID values for example. As an

additional enhancement, the EEPROM can be used to pre-program the UART, allowing pre-configuration, without requiring device driver changes. This allows the enhanced features of the integrated UART to be in place prior to handover to any generic device drivers.

Note that a default set of tuples is provided for both operating modes thus allowing for a single chip solution in either mode. 'Generic' normal mode can also be implemented through EEPROM configuration.

## 5 PCMCIA / CF TARGET CONTROLLER

### 5.1 Operation

Note: See section 0 for timing waveforms.

The OXCF950 responds to a number of different CF/PCMCIA accesses (detailed below). Section 0 contains timing diagrams and information for each of these types of access.

- Direct Common Memory read/writes:** These are required in Local Bus mode only to allow indirect access to attribute memory. This type of access is permitted before and after configuration to allow the reading of the CIS information, but is only supported by the PCMCIA specification. Only 8 bit data, even byte accesses are performed to this memory as it is only used for access to the indirect attribute memory. If the host attempts to access an invalid address, the value of 0xFF (null) is returned.
- Direct Attribute Memory read/writes:** Access to direct attribute memory is required in both CF and PCMCIA specifications. This memory space contains all the configuration information for the device, as well as the configuration registers. In CF systems, where only direct access is permitted, this space is the only memory space that is accessed by the host system. If the host attempts to access common memory in this mode, the device will return 0xFF telling the host that there is no valid data in this space. In Local Bus Mode, the direct attribute memory informs the host that indirect access is enabled allowing the host to perform indirect access to attribute memory, via common memory. Valid data is 8 bits wide and on even bytes only, for direct attribute memory (as defined in the PCMCIA 7.1 standard)
- Indirect Attribute Memory read/writes (Local Bus mode only):** Access to indirect attribute memory is performed through direct common memory. This allows the device to provide full functionality with only 4 address pins. This access is performed to read the CIS and also read/write to configuration registers. Valid data is 8 bit wide and on even bytes only, for indirect attribute memory (as defined in the PCMCIA 7.1 standard).
- IO read/writes:** IO accesses are performed to access the UART, local bus (Local Bus mode) and local configuration registers. Data width is restricted to 8 bits, as required by the standard UART function. As the device CIS information configures the card as a single function device, no base addresses need to be

defined thus simplifying access to the function. As reads and writes are immediate, there is no requirement to hold the WAIT# signal in its active state, thus providing maximum speed access to IO space.

### 5.2 Configuration Space (Card Information Structure)

#### 5.2.1 Local Bus Mode Space Map

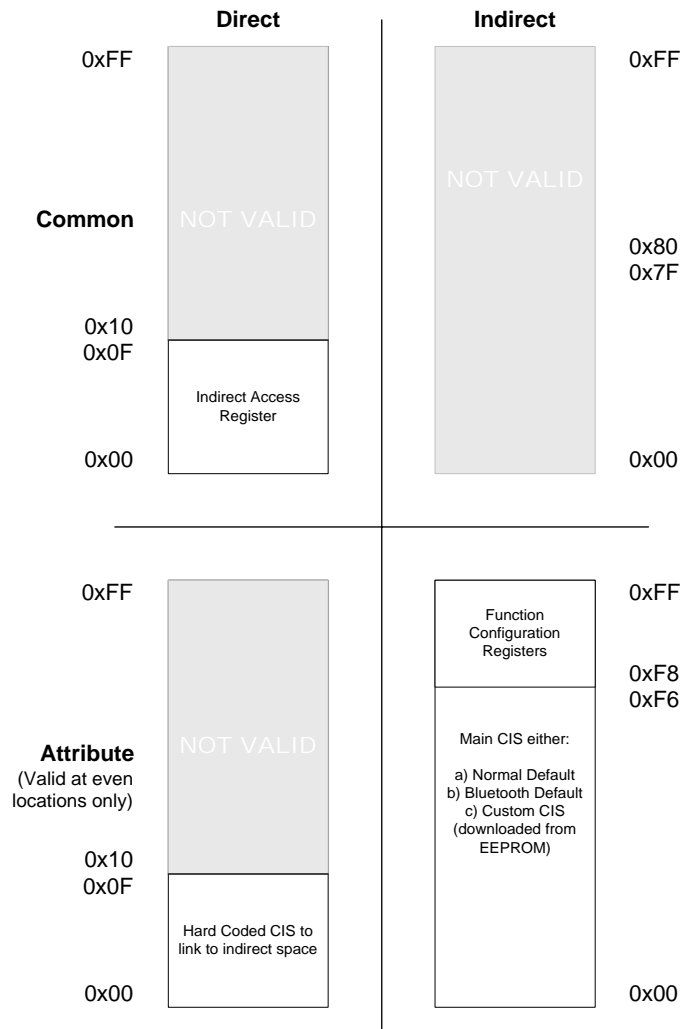

Figure 4: Local Bus mode memory space map

5.2.2 Normal Mode Space Map

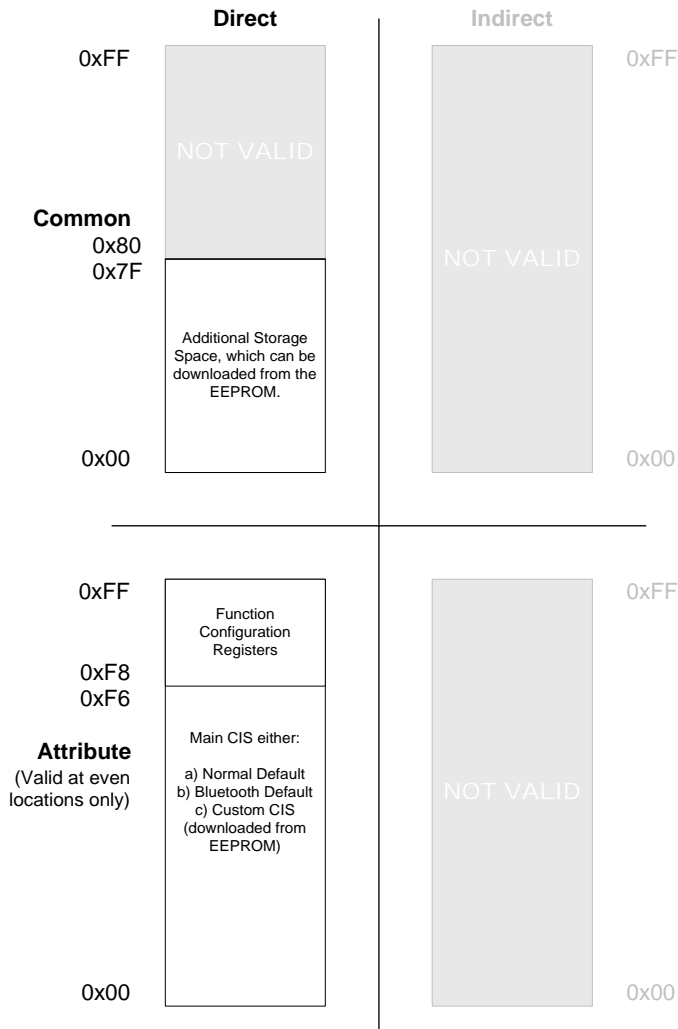

Figure 5: Normal Mode memory space map

5.3 Access to IO Function

5.3.1 Access to Internal UART

Access to the internal UART is achieved via standard IO mapping. As the device is configured as a single function device, no base address is required to access the UART. As IO mapping is used, access to the UART is permitted only after the card has been configured. Once the Configuration Options Register has been set in the Attribute area, the UART can be accessed following the mapping shown in Table 4.

UART Address (hex)	CF/PCMCIA offset from address 0 for UART function in IO space (hex)
0	0
1	1
2	2
3	3
4	4
5	5
6	6
7	7

Table 4: UART's mapping in I/O space

5.3.2 Access to Local Bus

Access to the internal Local Bus is achieved via standard IO mapping. The Local Bus function is available in Local Bus mode only as it's device pins are used as the extended address bits required for direct access in Normal mode. Indirect access is only supported in the PCMCIA specification, so the local bus is only available in PCMCIA systems. As the device is configured as a single function device, no base address is required to access the Local Bus. As IO mapping is used, access to the Local Bus is permitted only after the card has been configured. Once the Configuration Options Register has been set in the Attribute area, the Local Bus can be accessed following the mapping shown in Table 5. This access is permitted only if bit[0] is reset to '0' in the MDR register in the UART, otherwise the local configuration registers will be accessed rather than the local bus.

Local Bus Address <sup>1</sup> (hex)	CF/PCMCIA offset from address 0 for Local Bus function in IO space (hex)
0	8
1	9
2	A
3	B
4	C
5	D
6	E
7	F

Note 1: Although only 4 bits of IO address space are requested by the default CIS in the device, the address range may be extended past these four bits. This can be achieved by modifying the CIS, via the EEPROM, and connecting the extended address bits to the external local bus device. A3 is used by the OXCF950 to determine internal/external accesses, so a linear address range for external devices over 8 addresses is not possible.

Table 5: Local Bus mapping in I/O space

### 5.3.3 Accessing Local Configuration Registers

The local configuration registers are a set of device specific registers, which can be accessed via standard IO mapping. As the device is configured as a single function device, no base address is required to access the local configuration registers. Since IO mapping is used, access to the local configuration registers is permitted only after the card has been configured. Once the Configuration Options Register has been set in the Attribute area, the local configuration registers can be accessed following the mapping shown in Table 6. This access is always permitted in Normal Mode. In Local Bus Mode access is only permitted if bit[0] is set to '1' in the MDR register in the UART, otherwise the local bus will be accessed rather than the local configuration registers. In Generic Normal mode, the MDR register causes the configuration registers to overlay the UART address space (0 to 7).

Since the local configuration registers can be accessed in a variety of ways, it can complicate driver writing tasks. The following sequence can be used to ensure correct access in Generic, Normal or Local Bus Modes.

1. Write to UART SPR register (offset 7) with 0xFE. This sets the ICR to point to the MDR register.
2. Write to UART ICR register (offset 5) with 0x01. This sets bit 0 of the MDR register. The configuration registers are now accessible, but they may be in address range 0 to 7 or 8 to 15 depending on Generic mode or not.
3. Read offset 7. If bit 7 is set, the configuration registers can be found in the offset address range 8 to 15. If bit 7 is clear, the registers are overlaying the UART registers and can be found in the offset address range 0 to 7.
4. Using the offset discovered in (3) access the required local configuration registers.
5. Write to offset 7 with 0xfe, followed by a write to offset 5 with 0. This will switch back to normal operation.

CF/PCMCIA offset from address 0 for local configuration registers in IO space (hex)	Register Map
8 (0 in Generic mode)	EEPROM Status and Control register
9 (1 in Generic mode)	Multi-Purpose I/O Configuration register
A (2 in Generic mode)	UART Divider/Interrupt Pulse Width Divider register
B (3 in Generic mode)	Mode Status register
C (4 in Generic mode)	Interrupt Status register
D (5 in Generic mode)	Soft UART/Local Bus reset register
E (6 in Generic mode)	Generic Mode control
F (7 in Generic mode)	Page switch out control (in Generic Mode)

Table 6: Local Configuration Register's mapping in I/O space

Each of the local configuration registers are explained in the following sections. The offsets assume normal or local bus mode, and these are the offsets that should be used when accessing the registers via the EEPROM.

*EEPROM Status and Control register 'ESC'(Offset 0x08)*

This register defines the control on the serial EEPROM. The individual bits are described in Table 7.

Bits	Description	Read/Write		Reset
		EEPROM	PCMCIA	
7:6	Reserved	-	R	000
5	EEPROM Overrun. Set when an invalid EEPROM image causes the end of the EEPROM to be read before the end of the programming sequence. In this state the OXCF950 is set as though no EEPROM is attached. <i>This feature is new to OXCF950 rev B</i>	-	R	0
4	EEPROM Data In. For reads from the EEPROM this input bit is the output-data (DO) of the external EEPROM connected to EE_DI pin	-	R	X
3	EEPROM Data Out. For writes to the EEPROM, this output bit feeds the input-data of the external EEPROM (DI). This bit is output on the devices EE_DO and clocked into the EEPROM by EE_CK	-	R/W	0
2	EEPROM Clock. For reads or writes to the external EEPROM toggle this bit to generate an EEPROM clock (EE_CK pin)	-	R/W	0
1	EEPROM Chip Select. When '1' the EEPROM chip select pin EE_CS is activated (high). When '0' EE_CS is de-activated (low)	-	R/W	0
0	EEPROM Valid A '1' indicates that a valid EEPROM program header is present	-	R	X

Table 7: EEPROM Status and Control Register

*Multi-Purpose I/O Configuration register 'MIC' (Offset 0x09)*

This register configures the operation for the multi-purpose I/O pins 'MIO[1:0]' as follows

Bits	Description	Read/Write		Reset
		EEPROM	PCMCIA	
7:4	Reserved	-	R	0000
3:2	MIO1 Configuration register 00 -> MIO1 is a non-inverting input pin 01 -> MIO1 is an inverting input pin 10 -> MIO1 is an output pin driving '0' 11 -> MIO1 is an output pin driving '1'	W	R/W	00
1:0	MIO0 Configuration register 00 -> MIO0 is a non-inverting input pin 01 -> MIO0 is an inverting input pin 10 -> MIO0 is an output pin driving '0' 11 -> MIO0 is an output pin driving '1'	W	R/W	00

Table 8: Multi Purpose I/O Configuration Register



*UART Divider/Interrupt Pulse Width Divider register 'DIV' (Offset 0x0A)*

This register defines the divide values ( $2^N$  division) for the clocks to the UART and Interrupt pulse generator signal. This allows the device to be set up in its lowest power mode possible, and is fully programmable by the host or the EEPROM. The default value for the UART clock divider provides a clock to the UART of x1. The default value for the Interrupt pulse divider provides a clock to the interrupt processor of /32. See Section 5.4.1 Note that the UART clock rate should not be changed without then resetting the UART(see SRT register).

Bits	Description	Read/Write		Reset
		EEPROM	PCMCIA	
7:6	Reserved	-	R	00
5:3	Uart clock divide value. The division ratio is $2^N$ , giving 1, 2, 4, 8, 16, 32, 64, 128	W	R/W	000
2:0	Interrupt Pulse divide value: This field should be set under the following clock freq. conditions 000 -> when clock frequency is less than 2MHz 001 -> when clock frequency is between 2 and 4MHz 010 -> when clock frequency is between 4 and 8MHz 011 -> when clock frequency is between 8 and 16MHz 100 -> when clock frequency is between 16 and 32MHz 101 -> when clock frequency is between 32 and 64MHz 110 -> RESERVED 111 -> RESERVED	W	R/W	101

Table 9: UART Divider/ Interrupt Pulse Width Divider

*Mode Status register 'MSR' (Offset 0x0B)*

This read only register return the state of the MODE pin (i.e. whether in Normal or Local Bus modes).

Bits	Description	Read/Write		Reset
		EEPROM	PCMCIA	
7:1	Reserved	-	R	0000000
0	Mode 0 = Normal, 1 = Local Bus	-	R	X

Table 10: Mode Status Register

*Interrupt Status and Control register 'ISR' (Offset 0x0C)*

This register controls the assertion of interrupts from the User I/O pins (MIO[1:0]) as well as returning the internal status of the interrupt sources.

Bits	Description	Read/Write		Reset
		EEPROM	PCMCIA	
7:5	Reserved	-	R	000
4	UART Interrupt status This bit reflects the state of the internal UART interrupt	-	R	0
3	MIO[1] interrupt mask When set to '1' allows pin MIO[1] to assert an interrupt on the devices IREQ# pin. The state of the MIO[1] signal that causes an interrupt is dependent upon the polarity set by the register fields MIC[3:2].	W	R/W	0
2	MIO[0] interrupt mask When set to '1' allows pin MIO[0] to assert an interrupt on the devices IREQ# pin. The state of the MIO[0] signal that causes an interrupt is dependent upon the polarity set by the register fields MIC[1:0].	W	R/W	0
1	MIO1 Internal state This bit reflects the state of the internal MIO[1]. The internal MIO[1] signal reflects the non-inverted or inverted state of MIO[1] pin	-	R	X
0	MIO0 Internal state This bit reflects the state of the internal MIO[0]. The internal MIO[0] signal reflects the non-inverted or inverted state of MIO[0] pin	-	R	X

Table 11: Interrupt Status Register

*Soft UART/Local Bus reset register 'SRT' (Offset 0x0D)*

This register controls the soft reset passed to the UART and local bus reset. These reset lines are in addition to the soft reset that may be produced by the host (bit[7] of the COR register in attribute memory space). Note that the local bus reset is used in Local Bus mode only and not in Normal mode. Note these bits are not self-clearing.

Bits	Description	Read/Write		Reset
		EEPROM	PCMCIA	
7:2	Reserved	-	R	000000
1	Active high soft reset for UART	W	R/W	0
0	Active high soft reset for Local Bus	W	R/W	0

Table 12: Soft UART / Local Bus Reset (LB reset used in Local Bus Mode only)

*Generic Mode Control register 'GMC' (Offset 0x0E)*

This register provides EEPROM control for the pin-selectable Generic mode. When set, only the bottom 3 address bits are decoded for UART access, and paging is required to switch to configuration registers. It is up to the user to ensure the CIS tuples also request only an 8 bit address range if this is programmed via the EEPROM (i.e. CIS entries will be needed as well).

Bits	Description	Read/Write		Reset
		EEPROM	PCMCIA	
0	Generic Mode Address Decode Enables Generic Mode decoding when '1'. This should only be set in Normal mode (MODE = '0') <i>This feature is new to OXCF950 rev B</i>	W	R	0

Table 13: Generic Mode Control

Generic Page Switch register 'GPS' (Offset 0x0F)

This register provides a mechanism for the user to switch out of accessing the configuration registers when in Generic mode i.e. when the configuration registers overlay the UART registers.

Bits	Description	Read/Write		Reset
		EEPROM	PCMCIA	
0	Write 0 to switch out of overlay mode <i>This feature is new to OXCF950 rev B</i>	-	W	0

Table 14: Generic Page Switch

5.4 CF / PCMCIA Interrupt

5.4.1 Interrupt Generation

PCMCIA/CF cards support pulse or level type interrupt signals to request interrupt service from the host system. The CIS of the card specifies whether pulse, level or both types of interrupt can be generated. Once the host has read the CIS it is able to set the LevReq field in the Configuration Options Register (COR) to tell the card which type of interrupts should be generated.

The OXCF950 is capable of generating either type of interrupt. However, to reduce power consumption, the default CIS states that only level type interrupts can be generated. A custom CIS can be constructed that specifies the card has the ability to generate pulse type interrupts, if this is required, by using an external EEPROM.

The OXCF950 uses a programmable clock divider circuit to generate pulse type interrupts signals. The pulse that is generated is one clock cycle (after division) in length. The divider circuit can be programmed by setting the contents of the Interrupt Pulse Divide Value field in the DIV local configuration register (see section 6.3.4.3). This allows the length of the pulse to be varied, so that different clock frequencies can be used and the pulse can still be kept as short as possible, without violating the minimum length of 50 μs as defined in the PCMCIA Standard. Table 15 shows how the register should be programmed for different clock frequencies.

Clock Frequency (MHz)				Interrupt Divider Setting
	f	<	2	000
2	<=	f	< 4	001
4	<=	f	< 8	010
8	<=	f	< 16	011
16	<=	f	< 32	100
32	<=	f	< 64	101
RESERVED				110
RESERVED				111

Table 15: Interrupt Pulse Divide Value settings

5.4.2 Interrupt Sources

The OXCF950 has three possible interrupt sources. These are the internal UART, and the two multi-purpose I/O pins, which can be configured as interrupts using the MIO Configuration Register (MIC – see section 6.3.4.2) and the Interrupt Status and Control Register (ISR – see section 6.3.4.5)

When the OXCF950 is requesting interrupt service, the Intr field within the Configuration Status Register (CSR – see section 6.5.2) will be set to 1. Otherwise this field will be cleared to 0. The Intr field value is controlled by the interrupt source (i.e UART or MIO [1:0]). The status of the actual interrupts can be read from the ISR register.

### 5.5 CF/PCMCIA Function Configuration Registers

Each PCMCIA/CF card's I/O function must implement Function Configuration Registers (FCR). These registers allow the host to configure the function provided by the card, and are mapped into the attribute memory space at the location specified within the CONFIG tuple (in the CIS). The CONFIG tuple defines a base address for the Function Configuration Registers and a number corresponding to how many registers are supported (4 registers in the OXCF950). Each of these registers has read/write capability and is mapped at even location, consistent with the design of attribute memory. The registers supported in the OXCF950 are shown in the following table.

Offset from FCR base address	Attribute memory address	Register
0	F8	Configuration Options Register
2	FA	Configuration and Status Register
4	FC	Pin Replacement Register
8	FE	Socket & Copy Register

Table 16: Configuration Register Mapping

Due to the type of function the OXCF950 configures the card to be, and the fact that it is a single function device, only a sub-set of the total number of configuration registers are required.

The definition of each configuration register is detailed in the next few sub-sections.

#### 5.5.1 Configuration Options Register 'COR' (offset 0xF8)

The configuration options register is used to configure PCMCIA/CF cards that have programmable address decoders. Once the card's client driver has successfully parsed the CIS, it will attempt to obtain system resources, as requested by the CIS. On completion of this it assigns the resources to the card via the COR. The COR format and description is given in Table 17.

D7	D6	D5	D4	D3	D2	D1	D0
SRESET	LevlREQ	Function Configuration Index					

Field	Type	Description
SRESET	R/W	Software reset Setting this field to '1' places the card in the reset state. This is equivalent to setting the RESET signal (on pin) except this SRESET field is not reset. Returning this field to '0' leaves the card in the same un-configured, reset state as the card would be following a power-up and hard reset.
LevlREQ <sup>1</sup>	R/W	Level Mode IREQ# Setting this field to '1' enables level type interrupts Setting this field to '0' enables pulse type interrupts
Function Configuration Index	R/W	Configuration Index The host sets this field to the value of the Configuration Entry Number field of a Configuration Table Entry tuple as defined in the CIS. On setting the non-zero value in this field the function IO is enabled and IO accesses are allowed. When the field is set to zero (e.g. after a hard reset) the card will be configured to memory only mode and all IO accesses will be ignored by the card.

Table 17: Configuration Option Register

**Note 1**

The default tuples in the CIS tell the host that only level type interrupts are supported to allow lowest power consumption. The OXCF950 supports both level and pulse type interrupts, and if a particular manufacturer requires to use pulse type, or both, then the CIS can be modified using the external EEPROM.

5.5.2 Configuration Status Register 'CSR' (Offset 0xFA)

The Configuration and Status Register is an optional register, supported by the OXCF950. The register allows additional control over a function's configuration and reports status related to the function's configuration.

D7	D6	D5	D4	D3	D2	D1	D0
Changed	SigChg	IOIs8	RFU	Audio	PwrDwn	Intr	IntrAck

Field	Type	Description
Changed	R	<p>If a PCMCIA/CF card is using the I/O interface, the function's Pin Replacement register is present and one or more of the state change signals in the Pin Replacement Register are set to one(1), or one Event bits in the Extended Status Register are set (1) and the corresponding Enable bit is set (1), the function shall set this field to one (1).</p> <p>If a PCMCIA/CF card is not using the I/O interface or the function's Pin Replacement register is not present, this field is undefined and should be ignored.</p>
SigChg <sup>1</sup>	R/W	<p>This field serves as a gate for STSCHG#</p> <p>If a PCMCIA/CF card is using the I/O interface and both the Changed and SigChg fields are set to one (1), the function shall assert STSCHG#.</p> <p>If a PCMCIA/CF card is using the I/O interface and this field is reset to zero (0), the function shall not assert STSCHG#.</p> <p>If a PCMCIA/CF card is not using the I/O interface or the function's Pin Replacement register is not present, this field is undefined and should be ignored.</p>
IOIs8	R/W	The host sets this field to one (1) when it can provide I/O cycles only with an 8-bit D[7..0] data path. The card is guaranteed that accesses to the 16-bit registers will occur as two byte accesses rather than as a single 16-bit access.
RFU	-	Reserved. Must be zero (0).
Audio <sup>2</sup>	R/W	This bit is set to one (1) to enable audio information on SPKR# when the card is configured.
PwrDwn <sup>3</sup>	R/W	<p>When the host sets this field to one (1), the function shall enter a power-down state, if such a state exists.</p> <p>If a PCMCIA/CF card function does not have a power-down state, the function shall ignore this field.</p>
Intr	R	<p>Interrupt Request / Acknowledge – This field reports whether the function is requesting interrupt servicing and may be used to acknowledge the host system is ready to process another interrupt request from the PCMCIA/CF card.</p> <p>The function shall set this field to one (1) when it is requesting interrupt service. The function shall set this field to zero (0) when it is not requesting interrupt service.</p> <p>Writes to this field are ignored when the IntrAck field of all Configuration and Status Registers on the PCMCIA/CF card are reset to zero (0).</p>
IntrAck	R/W	Single function cards ignore this field on writes and always return zero (0).

Table 18: Configuration Status Register

Note 1

The STSCHG# signal is optional and is not supported on the OXCF950, to reduce the complexity of the device.

**Note 2**

Audio is not supported on the device.

**Note 3**

The OXCF950 does not support a specific power down mode, since it is a low power device that features a number of sleep modes (see Section 6 for further details).

**5.5.3 Pin Replacement Register 'PRR' (Offset 0xFC)**

The Pin Replacement Register is implemented to provide information about READY, WP or the BVD[2..1] status when implementing the I/O interface.

D7	D6	D5	D4	D3	D2	D1	D0
CBVD1	CBVD2	CREADY	CWProt	RBVD1	RBVD2	RREADY	RWProt

Field	Description
CBVD1	This bit is set (1) when the corresponding bit, RBVD1, changes state. This bit may also be written by the host.
CBVD2	This bit is set (1) when the corresponding bit, RBVD2, changes state. This bit may also be written by the host.
CREADY	This bit is set (1) when the corresponding bit, RREADY, changes state. This bit may also be written by the host.
CWProt	This bit is set (1) when the corresponding bit, RWProt, changes state. This bit may also be written by the host.
RBVD1	When read, this bit represents the internal state of the Battery Voltage Detect circuits which would be on the BVD1 pin.  When this bit is written as 1 the corresponding CBVD1 bit is also written. When this bit is written as 0, the CBVD1 bit is unaffected.
RBVD2	When read, this bit represents the internal state of the Battery Voltage Detect circuits which would be on the BVD2 pin.  When this bit is written as 1 the corresponding CBVD2 bit is also written. When this bit is written as 0, the CBVD2 bit is unaffected.
RREADY	When read, this bit represents the internal state of the READY signal. This bit may also be used to determine the state of READY as that pin has been relocated for use as Interrupt Request on IO Cards.  When this bit is written as 1 the corresponding "changed" bit is also written. When this bit is written as 0, the "changed" bit is unaffected.
RWProt	When read, this bit represents the state of the WP signal. This signal may also be used to determine the state of the Write Protect switch when pin 33 is being used for IOIS16#.  When this bit is written as 1 the corresponding "changed" bit is also written. When this bit is written as 0, the "changed" bit is unaffected.

Table 19: Pin Replacement Register

**5.5.4 Socket and Copy Register 'SCR' (Offset 0xFE)**

This is an optional read/write register, implemented by the OXCF950, which the PCMCIA/CF card may use to distinguish between similar cards installed in a system. This register is always written by the system before writing the card's Function Configuration Index field in the Configuration Option register.

D7	D6	D5	D4	D3	D2	D1	D0
Reserved	Copy Number			Socket Number			

Field	Description
Reserved	This bit is reserved for future standardization. This bit must be set to zero (0) by software when the register is written.
Copy Number	PCMCIA/CF cards that indicate in their CIS that they support more than one copy of identically configured cards, should have a copy number (0 to MAX twin cards, MAX = n-1) written back to the socket and Copy register.  This field indicates to the card that it is the n'th copy of the card installed in the system, which is identically configured. The first card installed receives the value 0. This permits identical cards designed to share a common set of I/O ports while remaining uniquely identifiable and consecutively ordered.
Socket Number	This field indicates to the PCMCIA/CF card that it is located in the n'th socket. The first socket is numbered 0. This permits any cards designed to do so to share a common set of I/O ports while remaining uniquely identifiable.

Table 20: Socket and Copy Register

**5.6 Card Information Structure**

**5.6.1 Local Bus Mode**

Value (Hex)	Tuple Name	Description
<b>Direct Attribute</b>		
0x01 0x02 0x00 0xFF	CISTPL_DEVICE	CIS should start with a CISTPL_DEVICE tuple.
0x03 0x00	CISTPL_INDIRECT	Use indirect access register (located in direct common memory).
0xFF	CISTPL_END	
<b>Indirect Attribute</b>		
0x13 0x03 0x43 0x49 0x53	CISTPL_LINKTARGET	The first tuple in indirect memory must be a CISTPL_LINKTARGET to prove that a valid CIS chain is present. The host will start processing from location 0 of the indirect attribute memory, after following an implied link from the primary CIS chain in direct attribute memory.
0x1C 0x03 0x03 0x00 0xFF	CISTPL_DEVICE_OC	This tuple allows the device to be operated at 3.3 volts as well as at 5.0 volts.
0x20 0x04 0x79	CISTPL_MANFID	This tuple specifies the manufacturer ID and product ID codes (0x0279 and 0x950B respectively).

0x02 0x0B 0x95		
0x21 0x02 0x02 0x01	CISTPL_FUNCID	This tuple specifies the function of the device, in this case the tuple states the device is a serial port.
0x22 0x04 0x00 0x02 0x0F 0x7F	CISTPL_FUNCE	This tuple is the function extension tuple, and provides more detailed information about the function of the device, and provides the following information: <ul style="list-style-type: none"> <li>• Serial port includes a 16550 compatible UART.</li> <li>• Space, Mark, Odd and Even parity</li> <li>• 5, 6, 7, 8 bit chars</li> <li>• 1, 1.5 and 2 stop bit operation.</li> </ul>
0x15 0x15 0x07 0x01 0x50 0x43 0x20 0x43 0x41 0x52 0x44 0x00 0x47 0x45 0x4E 0x45 0x52 0x49 0x43 0x00 0x00 0x00 0xFF	CISTPL_VERS_1	The Level 1 version / product information tuple provides the host with the following information: <ul style="list-style-type: none"> <li>• The device supports version 7.1 of the PC Card Specification.</li> <li>• The Manufacturer String is "PC CARD"</li> <li>• The Product String is "GENERIC"</li> <li>• The Additional Product Information strings are empty.</li> </ul>
0x1A 0x04 0x00 0x02 0xF8 0x0F	CISTPL_CONFIG	The CISTPL_CONFIG tuple provides basic configuration information including the following: <ul style="list-style-type: none"> <li>• Base address of the configuration registers (specified as 0xFA)</li> <li>• Which configuration registers are present and supported (Configuration Options Register, Configuration Status Register, Pin Replacement Register, and Socket and Copy Register are supported).</li> <li>• Index of the last Configuration Table Entry (set to 0x02).</li> </ul>
0x1B 0x0D 0xC1 0x41 0x99 0x01 0xB5 0x1E 0xA0 0x40	CISTPL_CFTABLE_ENTRY	This tuple specifies one particular configuration that the device can be used in. Each configuration has an index number, which is used by the host to select it. This configuration has the following properties: <ul style="list-style-type: none"> <li>• Index is 0x01</li> <li>• READY signal is active, and configuration is for I/O and Memory mode.</li> <li>• Nominal Vcc is set to be 3.30 volts.</li> <li>• Requests 16 bytes of I/O space.</li> <li>• Level interrupts, interrupt sharing are supported.</li> <li>• Any interrupt (IRQ0-15) can be used.</li> <li>• Maximum number of identical cards is set to 8.</li> </ul>



0x0F 0xB0 0xFF 0xFF 0x07		
0x1B 0x04 0x02 0x01 0x01 0x55	CISTPL_CFTABLE_ENTRY	This configuration is based on the previous configuration, except that it requests Vcc to be 5.0 volts.
0xFF	CISTPL_END	End of CIS

Table 21: Card Information Structure Values (Local Bus Mode)

5.6.2 Normal Mode

Value (Hex)	Tuple Name	Description
<b>Direct Attribute</b>		
0x01 0x03 0x00 0x00 0xFF	CISTPL_DEVICE	CIS should start with a CISTPL_DEVICE tuple. (Allows operation at 5.0 volts)
0x1C 0x03 0x03 0x00 0xFF	CISTPL_DEVICE_OC	The CISTPL_DEVICE_OC tuple allows operation at 3.3 volts.
0x20 0x04 0x79 0x02 0x0B 0x95	CISTPL_MANFID	This tuple specifies the manufacturer ID and product ID codes (0x0279 and 0x950B respectively).
0x21 0x02 0x02 0x01	CISTPL_FUNCID	This tuple specifies the function of the device, in this case the tuple states the device is a serial port.
0x22 0x04 0x00 0x02 0x0F 0x7F	CISTPL_FUNCE	This tuple is the function extension tuple, and provides more detailed information about the function of the device, and provides the following information: <ul style="list-style-type: none"> <li>• Serial port includes a 16550 compatible UART.</li> <li>• Space, Mark, Odd and Even parity</li> <li>• 5, 6, 7, 8 bit chars</li> <li>• 1, 1.5 and 2 stop bit operation.</li> </ul>

0x15 0x15 0x07 0x01 0x43 0x46 0x20 0x43 0x41 0x52 0x44 0x00 0x47 0x45 0x4E 0x45 0x52 0x49 0x43 0x00 0x00 0x00 0xFF	CISTPL_VERS_1	<p>The Level 1 version / product information tuple provides the host with the following information:</p> <ul style="list-style-type: none"> <li>• The device supports version 7.1 of the PC Card Specification.</li> <li>• The Manufacturer String is "CF CARD"</li> <li>• The Product String is "GENERIC"</li> </ul> <p>The Additional Product Information strings are empty.</p>
0x1A 0x04 0x00 0x04 0xF8 0x0F	CISTPL_CONFIG	<p>The CISTPL_CONFIG tuple provides basic configuration information including the following:</p> <ul style="list-style-type: none"> <li>• Base address of the configuration registers (specified as 0xF8)</li> <li>• Which configuration registers are present and supported (Configuration Options Register, Configuration Status Register, Pin Replacement Register, and Socket and Copy Register are supported).</li> <li>• Index of the last Configuration Table Entry (set to 0x04).</li> </ul>
0x1B 0x0F 0xC1 0x41 0x99 0x01 0xB5 0x1E 0xA8 0x60 0xF8 0x03 0x0F 0xB0 0xFF 0xFF 0x07	CISTPL_CFTABLE_ENTRY	<p>This tuple specifies one particular configuration that the device can be used in. Each configuration has an index number, which is used by the host to select it. This configuration has the following properties:</p> <ul style="list-style-type: none"> <li>• Index is 0x01</li> <li>• READY signal is active, and configuration is for I/O and Memory mode.</li> <li>• Nominal Vcc is set to be 3.30 volts.</li> <li>• Requests 16 bytes of I/O space, starting at 0x03F8.</li> <li>• Level interrupts, interrupt sharing are supported.</li> <li>• Any interrupt (IRQ0-15) can be used.</li> <li>• Maximum number of identical cards is set to 8.</li> </ul>
0x1B 0x03 0x02 0x08 0x2F	CISTPL_CFTABLE_ENTRY	<p>This configuration is based on the previous configuration, except that it specifies the I/O space can start anywhere.</p>
0x1B 0x0E 0xC3 0x41	CISTPL_CFTABLE_ENTRY	<p>This tuple specifies one particular configuration that the device can be used in. Each configuration has an index number, which is used by the host to select it. This configuration has the following properties:</p> <ul style="list-style-type: none"> <li>• Index is 0x03</li> </ul>

0x99 0x01 0x55 0xA8 0x60 0xF8 0x03 0x0F 0xB0 0xFF 0xFF 0x07		<ul style="list-style-type: none"> <li>• READY signal is active, and configuration is for I/O and Memory mode.</li> <li>• Nominal Vcc is set to be 5.0 volts.</li> <li>• Requests 16 bytes of I/O space, starting at 0x03F8.</li> <li>• Level interrupts, interrupt sharing are supported.</li> <li>• Any interrupt (IRQ0-15) can be used.</li> <li>• Maximum number of identical cards is set to 8.</li> </ul>
0x1B 0x03 0x04 0x08 0x2F	CISTPL_CFTABLE_ENTRY	This configuration is based on the previous configuration, except that it specifies the I/O space can start anywhere.
0xFF	CISTPL_END	

Table 22: Card Information Structure Values (Normal Mode)

5.6.3 Generic Normal Mode

Value (Hex)	Tuple Name	Description
<b>Direct Attribute</b>		
0x01 0x03 0x00 0x00 0xFF	CISTPL_DEVICE	CIS should start with a CISTPL_DEVICE tuple. (Allows operation at 5.0 volts)
0x1C 0x03 0x03 0x00 0xFF	CISTPL_DEVICE_OC	The CISTPL_DEVICE_OC tuple allows operation at 3.3 volts.
0x20 0x04 0x79 0x02 0x0B 0x95	CISTPL_MANFID	This tuple specifies the manufacturer ID and product ID codes (0x0279 and 0x950B respectively).
0x21 0x02 0x02 0x01	CISTPL_FUNCID	This tuple specifies the function of the device, in this case the tuple states the device is a serial port.
0x22 0x04 0x00 0x02 0x0F 0x7F	CISTPL_FUNCE	<p>This tuple is the function extension tuple, and provides more detailed information about the function of the device, and provides the following information:</p> <ul style="list-style-type: none"> <li>• Serial port includes a 16550 compatible UART.</li> <li>• Space, Mark, Odd and Even parity</li> <li>• 5, 6, 7, 8 bit chars</li> <li>• 1, 1.5 and 2 stop bit operation.</li> </ul>

<p>0x15 0x15 0x07 0x01 0x43 0x46 0x20 0x43 0x41 0x52 0x44 0x00 0x47 0x45 0x4E 0x45 0x52 0x49 0x43 0x00 0x00 0x00 0xFF</p>	<p>CISTPL_VERS_1</p>	<p>The Level 1 version / product information tuple provides the host with the following information:</p> <ul style="list-style-type: none"> <li>• The device supports version 7.1 of the PC Card Specification.</li> <li>• The Manufacturer String is "CF CARD"</li> <li>• The Product String is "GENERIC"</li> </ul> <p>The Additional Product Information strings are empty.</p>
<p>0x1A 0x04 0x00 0x04 0xF8 0x0F</p>	<p>CISTPL_CONFIG</p>	<p>The CISTPL_CONFIG tuple provides basic configuration information including the following:</p> <ul style="list-style-type: none"> <li>• Base address of the configuration registers (specified as 0xF8)</li> <li>• Which configuration registers are present and supported (Configuration Options Register, Configuration Status Register, Pin Replacement Register, and Socket and Copy Register are supported).</li> <li>• Index of the last Configuration Table Entry (set to 0x04).</li> </ul>
<p>0x1B 0x0F 0xC1 0x41 0x99 0x01 0xB5 0x1E 0xA3 0x60 0xF8 0x03 0x07 0xB0 0xFF 0xFF 0x07</p>	<p>CISTPL_CFTABLE_ENTRY</p>	<p>This tuple specifies one particular configuration that the device can be used in. Each configuration has an index number, which is used by the host to select it. This configuration has the following properties:</p> <ul style="list-style-type: none"> <li>• Index is 0x01</li> <li>• READY signal is active, and configuration is for I/O and Memory mode.</li> <li>• Nominal Vcc is set to be 3.30 volts.</li> <li>• Requests 8 bytes of I/O space, starting at 0x03F8.</li> <li>• Level interrupts, interrupt sharing are supported.</li> <li>• Any interrupt (IRQ0-15) can be used.</li> <li>• Maximum number of identical cards is set to 8.</li> </ul>
<p>0x1B 0x05 0x02 0x08 0xA0 0x40 0x07</p>	<p>CISTPL_CFTABLE_ENTRY</p>	<p>This configuration is based on the previous configuration, except that it specifies the I/O space can start anywhere.</p>
<p>0x1B 0x0E</p>	<p>CISTPL_CFTABLE_ENTRY</p>	<p>This tuple specifies one particular configuration that the device can be used in. Each configuration has an index number, which is used by the host to select it. This</p>

<p>0xC3 0x41 0x99 0x01 0x55 0xA3 0x60 0xF8 0x03 0x07 0xB0 0xFF 0xFF 0x07</p>		<p>configuration has the following properties:</p> <ul style="list-style-type: none"> <li>• Index is 0x03</li> <li>• READY signal is active, and configuration is for I/O and Memory mode.</li> <li>• Nominal Vcc is set to be 5.0 volts.</li> <li>• Requests 8 bytes of I/O space, starting at 0x03F8.</li> <li>• Level interrupts, interrupt sharing are supported.</li> <li>• Any interrupt (IRQ0-15) can be used.</li> <li>• Maximum number of identical cards is set to 8.</li> </ul>
<p>0x1B 0x05 0x04 0x08 0xA0 0x40 0x07</p>	<p>CISTPL_CFTABLE_ENTRY</p>	<p>This configuration is based on the previous configuration, except that it specifies the I/O space can start anywhere.</p>
<p>0xFF</p>	<p>CISTPL_END</p>	

## 6 INTERNAL 950 UART

The internal UART within the OXCF950 is based on the 16C950 rev B, and is henceforth referred to as the 950 core. Some modes of the 16C950 rev B that are configured by pin options such as Extended-550 mode are not available in this embedded core.

### 6.1 Mode Selection

The 950 core is software compatible with the 16C450, 16C550, 16C654 and 16C750 UARTs. The operation of the 950 depends on a number of mode settings. These modes are referred to throughout this data sheet. The FIFO depth and compatibility modes are tabulated below:

UART Mode	FIFO size	FCR[0]	Enhanced mode (EFR[4]=1)	FCR[5] (guarded with LCR[7] = 1)
450	1	0	X	X
550	16	1	0	0
650	128	1	1	X
750	128	1	0	1
950*	128	1	1	X

Table 23: UART Mode Configuration

\* Note that 950 mode configuration is identical to 650 configuration

#### 6.1.1 450 Mode

After a hardware reset bit 0 of the FIFO Control Register ('FCR') is cleared, hence the 950 is compatible with the 16C450. The transmitter and receiver FIFOs (referred to as the 'Transmit Holding Register' and 'Receiver Holding Register' respectively) have a depth of one. This is referred to as 'Byte mode'. When FCR[0] is cleared, all other mode selection parameters are ignored.

#### 6.1.2 550 Mode

After a hardware reset, writing a 1 to FCR[0] will increase the FIFO size to 16, providing compatibility with 16C550 devices.

#### 6.1.3 750 Mode

Writing a 1 to FCR[0] will increase the FIFO size to 16. In a similar fashion to 16C750, the FIFO size can be further increased to 128 by writing a 1 to FCR[5]. Note that access to FCR[5] is protected by LCR[7]. I.e., to set FCR[5], software should first set LCR[7] to temporarily remove the guard. Once FCR[5] is set, the software should clear LCR[7] for normal operation.

The 16C750 additional features over the 16C550 are available as long as the UART is not put into Enhanced mode (i.e. EFR[4] should be '0'). These features are:

1. Deeper FIFOs
2. Automatic RTS/CTS out-of-band flow control
3. Sleep mode

#### 6.1.4 650 Mode

The 950 is compatible with the 16C650 when EFR[4] is set, i.e. the device is in Enhanced mode. As 650 software drivers usually put the device into Enhanced mode, running 650 drivers on the 950 will result in 650 compatibility with 128 deep FIFOs, as long as FCR[0] is set. Note that the 650 emulation mode of the 950 provides 128 byte deep FIFOs whereas the standard 16C650 has only 32 byte FIFOs.

650 mode has the same enhancements as the 16C750 over the 16C550, but these are enabled using different registers.

There are also additional enhancements over those of the 16C750 in this mode, these are:

1. Automatic in-band flow control
2. Special character detection
3. Infra-red "IrDA-format" transmit and receive mode
4. Transmit trigger levels
5. Optional clock prescaler

#### 6.1.5 950 Mode

The additional features offered in 950 mode generally only apply when the UART is in Enhanced mode (EFR[4]='1'). Provided FCR[0] is set, in Enhanced mode the FIFO size is 128.

Note that 950 mode configuration is identical to that of 650 mode, however additional 950 specific features are

enabled using the Additional Control Register 'ACR' (see section 6.11.3). In addition to larger FIFOs and higher baud rates, the enhancements of the 950 over the 16C654 are:

- Selectable arbitrary trigger levels for the receiver and transmitter FIFO interrupts
- Improved automatic flow control using selectable arbitrary thresholds
- DSR#/DTR# automatic flow control
- Transmitter and receiver can be optionally disabled
- Software reset of device
- Readable FIFO fill levels
- Optional generation of an RS-485 buffer enable signal
- Four-byte device identification (0x16C95008)
- Readable status for automatic in-band and out-of-band flow control
- External 1x clock modes (see section 6.10.4)
- Flexible "M N/8" clock prescaler (see section 6.10.2)
- Programmable sample clock to allow data rates up to 15 Mbps (see section 6.10.3)
- 9-bit data mode

The 950 trigger levels are enabled when ACR[5] is set (bits 4 to 7 of FCR are ignored). Then arbitrary trigger levels can be defined in RTL, TTL, FCL and FCH registers (see section 6.11). The Additional Status Register ('ASR') offers flow control status for the local and remote transmitters. FIFO levels are readable using RFL and TFL registers.

The UART has a flexible prescaler capable of dividing the system clock by any value between 1 and 31.875 in steps of 0.125. It divides the system clock by an arbitrary value in

"M N/8" format, where M and N are 5 and 3-bit binary numbers programmed in CPR[7:3] and CPR[2:0] respectively. This arrangement offers a great deal of flexibility when choosing an input clock frequency to synthesize arbitrary baud rates. The default division value is 4 to provide backward compatibility with 16C650 devices.

The user may apply an external 1x (or Nx) clock for the transmitter and receiver to the RI# and DSR# pin respectively. The transmitter clock may be asserted on the DTR# pin. The external clock options are selected through the CKS register (offset 0x02 of ICR).

It is also possible to define the over-sampling rate used by the transmitter and receiver clocks. The 16C450/16C550 and compatible devices employ 16 times over-sampling, i.e. There are 16 clock cycles per bit. However, the 950 can employ any over-sampling rate from 4 to 16 by programming the TCR register. This allows the data rates to be increased to 460.8 Kbps using a 1.8432MHz clock, or 15 Mbps using a 60 MHz clock. The default value after a reset for this register is 0x00, which corresponds to a 16 cycle sampling clock. Writing 0x01, 0x02 or 0x03 will also result in a 16 cycle sampling clock. To program the value to any value from 4 to 15 it is necessary to write this value into TCR i.e. to set the device to a 13 cycle sampling clock it would be necessary to write 0x0D to TCR. For further information see sections 6.10.3.

The 950 also offers 9-bit data frames for multi-drop industrial applications.

## 6.2 Register Description Tables

The three address lines select the various registers in the UART. Since there are more than 8 registers, selection of the registers is also dependent on the state of the Line Control Register 'LCR' and Additional Control Register 'ACR':

1. LCR[7]=1 enables the divider latch registers DLL and DLM.
2. LCR specifies the data format used for both transmitter and receiver. Writing 0xBF (an unused format) to LCR enables access to the 650 compatible register set. Writing this value will set LCR[7] but leaves LCR[6:0] unchanged. Therefore, the data format of the transmitter and receiver data is not affected. Write the desired LCR value to exit from this selection.
3. ACR[7]=1 enables access to the 950 specific registers.
4. ACR[6]=1 enables access to the Indexed Control Register set (ICR) registers as described on page 34.

Register Name	Address	R/W	Bit 7	Bit 6	Bit 5	Bit 4	Bit 3	Bit 2	Bit 1	Bit 0
THR <sup>1</sup>	000	W	Data to be transmitted							
RHR <sup>1</sup>	000	R	Data received							
IER <sup>1,2</sup> 650/950 Mode  550/750 Mode	001	R/W	CTS interrupt mask	RTS interrupt mask	Special Char. Detect	Sleep mode	Modem interrupt mask	Rx Stat interrupt mask	THRE interrupt mask	RxRDY interrupt mask
			Unused		Alternate sleep mode					
FCR <sup>3</sup> 650 mode  750 mode  950 mode	010	W	RHR Trigger Level		THR Trigger Level		DMA Mode / Tx Trigger Enable	Flush THR	Flush RHR	Enable FIFO
			RHR Trigger Level		FIFO Size	Unused				
			Unused							
ISR <sup>3</sup>	010	R	FIFOs enabled		Interrupt priority (Enhanced mode)		Interrupt priority (All modes)		Interrupt pending	
LCR <sup>4</sup>	011	R/W	Divisor latch access	Tx break	Force parity	Odd / even parity	Parity enable	Number of stop bits	Data length	
MCR <sup>3,4</sup> 550/750 Mode  650/950 Mode	100	R/W	Unused		CTS & RTS Flow Control	Internal Loop Back Enable	OUT2 (Int En)	OUT1	RTS	DTR
			Baud prescale	IrDA mode	XON-Any					
LSR <sup>3,5</sup> Normal 9-bit data mode	101	R	Data Error	Tx Empty	THR Empty	Rx Break	Framing Error	Parity Error	Overrun Error	RxRDY
								9 <sup>th</sup> Rx data bit		
MSR <sup>3</sup>	110	R	DCD	RI	DSR	CTS	Delta DCD	Trailing RI edge	Delta DSR	Delta CTS
SPR <sup>3</sup> Normal 9-bit data mode	111	R/W	Temporary data storage register and Indexed control register offset value bits							
			Unused							
Additional Standard Registers – These registers require divisor latch access bit (LCR[7]) to be set to 1.										
DLL	000	R/W	Divisor latch bits [7:0] (Least significant byte)							
DLM	001	R/W	Divisor latch bits [15:8] (Most significant byte)							

Table 24: Standard 550 Compatible Registers



Register Name	Address	R/W	Bit 7	Bit 6	Bit 5	Bit 4	Bit 3	Bit 2	Bit 1	Bit 0
To access these registers LCR must be set to 0xBF										
EFR	010	R/W	CTS flow control	RTS Flow control	Special char detect	Enhanced mode	In-band flow control mode			
XON1	100	R/W	XON Character 1							
9-bit mode			Special character 1							
XON2	101	R/W	XON Character 2							
9-bit mode			Special Character 2							
XOFF1	110	R/W	XOFF Character 1							
9-bit mode			Special character 3							
XOFF2	111	R/W	XOFF Character 2							
9-bit mode			Special character 4							

Table 25: 650 Compatible Registers

Register Name	Address	R/W	Bit 7	Bit 6	Bit 5	Bit 4	Bit 3	Bit 2	Bit 1	Bit 0
ASR <sup>1,6,7</sup>	001	R/W <sup>7</sup>	Tx Idle	FIFO size	FIFO-SEL	Special Char Detect	DTR	RTS	Remote Tx Disabled	Tx Disabled
RFL <sup>6</sup>	011	R	Number of characters in the receiver FIFO							
TFL <sup>3,6</sup>	100	R	Number of characters in the transmitter FIFO							
ICR <sup>3,8,9</sup>	101	R/W	Data read/written depends on the value written to the SPR prior to the access of this register (see Table 27)							

Table 26: 950 Specific Registers

*Register access notes:*

Note 1: Requires LCR[7] = 0

Note 2: Requires ACR[7] = 0

Note 3: Requires that last value written to LCR was not 0xBF

Note 4: To read this register ACR[7] must be = 0

Note 5: To read this register ACR[6] must be = 0

Note 6: Requires ACR[7] = 1

Note 7: Only bits 0 and 1 of this register can be written

Note 8: To read this register ACR[6] must be = 1

Note 9: This register acts as a window through which to read and write registers in the Indexed Control Register set

Register Name	SPR Offset <sup>10</sup>	R/W	Bit 7	Bit 6	Bit 5	Bit 4	Bit 3	Bit 2	Bit 1	Bit 0	
Indexed Control Register Set											
ACR	0x00	R/W	Additional Status Enable	ICR Read Enable	950 Trigger Level Enable	DTR definition and control		Auto DSR Flow Control Enable	Tx Disable	Rx Disable	
CPR	0x01	R/W	5 Bit "integer" part of clock prescaler					3 Bit "fractional" part of clock prescaler			
TCR	0x02	R/W	Unused				4 Bit N-times clock selection bits [3:0]				
CKS	0x03	R/W	Tx 1x Mode	Tx CLK Select	BDOUT on DTR	DTR 1x Tx CLK	Rx 1x Mode	Disable BDOUT	Receiver Clock Sel[1:0]		
TTL	0x04	R/W	Unused	Transmitter Interrupt Trigger Level (0-127)							
RTL	0x05	R/W	Unused	Receiver Interrupt Trigger Level (1-127)							
FCL	0x06	R/W	Unused	Automatic Flow Control Lower Trigger Level (0-127)							
FCH	0x07	R/W	Unused	Automatic Flow Control Higher Trigger level (1-127)							
ID1	0x08	R	Hardwired ID byte 1 (0x16)								
ID2	0x09	R	Hardwired ID byte 1 (0xC9)								
ID3	0x0A	R	Hardwired ID byte 1 (0x50)								
REV	0x0B	R	Hardwired revision byte (0x08)								
CSR	0x0C	W	Writing 0x00 to this register will reset the UART (Except the CKS and CKA registers)								
NMR	0x0D	R/W	Unused	9 <sup>th</sup> Bit SChar 4	9 <sup>th</sup> Bit SChar 3	9 <sup>th</sup> Bit SChar 2	9 <sup>th</sup> Bit SChar 1	9 <sup>th</sup> -bit Int. En.	9 Bit Enable		
MDM	0x0E	R/W	Unused				Δ DCD Wakeup disable	Trailing Rl edge disable	Δ DSR Wakeup disable	Δ CTS Wakeup disable	
RFC	0x0F	R	FCR[7]	FCR[6]	FCR[5]	FCR[4]	FCR[3]	FCR[2]	FCR[1]	FCR[0]	
GDS	0x10	R	Unused								Good Data Status
DMS	0x11	R/W	Force internal TxRdy inactive	Force internal RxRdy inactive	Unused				Internal TxRdy status (R)	Internal RxRdy status (R)	
PIDX	0x12	R	Hardwired Port Index ( 0x00 )								
CKA	0x13	R/W	Unused			Res. Write '0'	Res. Write '0'	Invert DTR signal	Invert internal tx clock	Invert internal rx clock	
MDR	0xFE	R/W	Unused								Cfg Paging control

Table 27: Indexed Control Register Set

Note 10: The SPR offset column indicates the value that must be written into SPR prior to reading / writing any of the indexed control registers via ICR. Offset values not listed in the table are reserved for future use and must not be used.

To read or write to any of the Indexed Control Registers use the following procedure.

Writing to ICR registers:

Ensure that the last value written to LCR was not 0xBF (reserved for 650 compatible register access value).  
 Write the desired offset to SPR (address 111<sub>2</sub>).  
 Write the desired value to ICR (address 101<sub>2</sub>).

Reading from ICR registers:

Ensure that the last value written to LCR was not 0xBF (see above).  
 Write 0x00 offset to SPR to select ACR.  
 Set bit 6 of ACR (ICR read enable) by writing x1xxxxx<sub>2</sub> to address 101<sub>2</sub>. Ensure that other bits in ACR are not changed.  
 (Software drivers should keep a copy of the contents of the ACR elsewhere since reading ICR involves overwriting ACR!)  
 Write the desired offset to SPR (address 111<sub>2</sub>).  
 Read the desired value from ICR (address 101<sub>2</sub>).  
 Write 0x00 offset to SPR to select ACR.  
 Clear bit 6 of ACR by writing x0xxxxx<sub>2</sub> to ICR, thus enabling access to standard registers again.

### 6.3 Reset Configuration

#### 6.3.1 Host Reset

After a hardware reset or soft reset (bit 7 of COR register), all writable registers are reset to 0x00, with the following exceptions:

1. DLL which is reset to 0x01.
2. CPR is reset to 0x20.

The state of read-only registers following a hardware reset is as follows:

RHR[7:0]: Indeterminate  
 RFL[6:0]: 0000000<sub>2</sub>  
 TFL[6:0]: 0000000<sub>2</sub>  
 LSR[7:0]: 0x60 signifying that both the transmitter and the transmitter FIFO are empty  
 MSR[3:0]: 0000<sub>2</sub>  
 MSR[7:4]: Dependent on modem input lines DCD, RI, DSR and CTS respectively  
 ISR[7:0]: 0x01, i.e. no interrupts are pending  
 ASR[7:0]: 1xx00000<sub>2</sub>  
 RFC[7:0]: 00000000<sub>2</sub>  
 GDS[7:0]: 00000001<sub>2</sub>

#### 6.4 Transmitter & Receiver FIFOs

Both the transmitter and receiver have associated holding registers (FIFOs), referred to as the transmitter holding register (THR) and receiver holding register (RHR) respectively.

In normal operation, when the transmitter finishes transmitting a byte it will remove the next data from the top of the THR and proceed to transmit it. If the THR is empty, it will wait until data is written into it. If THR is empty and the last character being transmitted has been completed

DMS[7:0]: 00000010<sub>2</sub>  
 CKA[7:0]: 00000000<sub>2</sub>

The reset state of output signals for are tabulated below:

Signal	Reset state
SOUT	Inactive High
RTS#	Inactive High
DTR#	Inactive High

Table 28: Output Signal Reset State

#### 6.3.2 Software Reset

An additional feature available in the 950 core is software resetting of the serial channel. The software reset is available using the CSR register. Software reset has the same effect as a hardware reset except it does not reset the clock source selections (i.e. CKS register and CKA register). To reset the UART write 0x00 to the Channel Software Reset register 'CSR'.

(i.e. the transmitter shift register is empty) the transmitter is said to be idle. Similarly, when the receiver finishes receiving a byte, it will transfer it to the bottom of the RHR. If the RHR is full, an overrun condition will occur (see section 6.5.3).

Data is written into the bottom of the THR queue and read from the top of the RHR queue completely asynchronously to the operation of the transmitter and receiver.

The size of the FIFOs is dependent on the setting of the FCR register. When in Byte mode, these FIFOs only accept one byte at a time before indicating that they are full; this is compatible with the 16C450. When in a FIFO mode, the size of the FIFOs is either 16 (compatible with the 16C550) or 128.

Data written to the THR when it is full is lost. Data read from the RHR when it is empty is invalid. The empty or full status of the FIFOs are indicated in the Line Status Register 'LSR' (see section 6.5.3). Interrupts can be generated or DMA signals can be used to transfer data to/from the FIFOs. The number of items in each FIFO may also be read back from the transmitter FIFO level (TFL) and receiver FIFO level (RFL) registers (see section 6.11.2).

**6.4.1 FIFO Control Register 'FCR'**

**FCR[0]: Enable FIFO mode**

- logic 0 ⇒ Byte mode.
- logic 1 ⇒ FIFO mode.

This bit should be enabled before setting the FIFO trigger levels.

**FCR[1]: Flush RHR**

- logic 0 ⇒ No change.
- logic 1 ⇒ Flushes the contents of the RHR

This is only operative when already in a FIFO mode. The RHR is automatically flushed whenever changing between Byte mode and a FIFO mode. This bit will return to zero after clearing the FIFOs.

**FCR[2]: Flush THR**

- logic 0 ⇒ No change.
- logic 1 ⇒ Flushes the contents of the THR, in the same manner as FCR[1] does for the RHR.

*DMA Transfer Signalling:*

**FCR[3]: DMA signalling mode / Tx trigger level enable**

- logic 0 ⇒ DMA mode '0'.
- logic 1 ⇒ DMA mode '1'.

DMA signals are not bonded out in the OXCF950, so this control only affects the transmitter trigger level in DMA mode 0.

**FCR[5:4]: THR trigger level**

Generally in 450, 550, extended 550 and 950 modes these bits are unused (see section 6.1 for mode definition). In 650 mode they define the transmitter interrupt trigger levels and in 750 mode FCR[5] increases the FIFO size.

*450, 550 and extended 550 modes:*

The transmitter interrupt trigger levels are set to 1 and FCR[5:4] are ignored.

*650 mode:*

In 650 mode the transmitter interrupt trigger levels are set to the following values:

FCR[5:4]	Transmit Interrupt Trigger level
00	16
01	32
10	64
11	112

Table 29: Transmit Interrupt Trigger Levels

These levels only apply when in Enhanced mode and in DMA mode 1 (FCR[3] = 1), otherwise the trigger level is set to 1. A transmitter empty interrupt will be generated (if enabled) if the TFL falls below the trigger level.

*750 Mode:*

In 750 compatible non-Enhanced (EFR[4]=0) mode, transmitter trigger level is set to 1, FCR[4] is unused and FCR[5] defines the FIFO depth as follows:

- FCR[5]=0 Transmitter and receiver FIFO size is 16 bytes.
- FCR[5]=1 Transmitter and receiver FIFO size is 128 bytes.

In non-Enhanced mode FCR[5] is only writable when LCR[7] is set. Note that in Enhanced mode, the FIFO size is also increased to 128 bytes when FCR[0] is set.

*950 mode:*

Setting ACR[5]=1 enables arbitrary transmitter trigger level setting using the TTL register (see section 6.11.4), hence FCR[5:4] are ignored.

**FCR[7:6]: RHR trigger level**

In 550, extended 550, 650 and 750 modes, the receiver FIFO trigger levels are defined using FCR[7:6]. The interrupt trigger level and upper flow control trigger level where appropriate are defined by L2 in the table below. L1 defines the lower flow control trigger level where applicable. Separate upper and lower flow control trigger levels introduce a hysteresis element in in-band and out-of-band flow control (see section 6.9).

FCR [7:6]	Mode					
	650		750		550	
	FIFO Size 128	FIFO Size 128	FIFO Size 128	FIFO Size 128	FIFO Size 16	FIFO Size 16
	L1	L2	L1	L2	L1	L2
00	1	16	1	1	n/a	1
01	16	32	1	32	n/a	4
10	32	112	1	64	n/a	8
11	112	120	1	112	n/a	14

Table 30: Receiver Trigger Levels

In Byte mode (450 mode) the trigger levels are all set to 1.

In all cases, a receiver data interrupt will be generated (if enabled) if the Receiver FIFO Level ('RFL') reaches the upper trigger level L2.

950 Mode:

When 950 trigger levels are enabled (ACR[5]=1), more flexible trigger levels can be set by writing to the TTL, RTL, FCL and FCH (see section 6.11) hence ignoring FCR[7:6].

## 6.5 Line Control & Status

### 6.5.1 False Start Bit Detection

On the falling edge of a start bit, the receiver will wait for 1/2 bit and re-synchronise the receiver's sampling clock onto the centre of the start bit. The start bit is valid if the SIN line is still low at this mid-bit sample and the receiver will proceed to read in a data character. Verifying the start bit prevents the receiver from assembling a false data character due to a low going noise spike on the SIN input.

Once the first stop bit has been sampled, the received data is transferred to the RHR and the receiver will then wait for a low transition on SIN signifying the next start bit.

The receiver will continue receiving data even if the RHR is full or the receiver has been disabled (see section 6.11.3) in order to maintain framing synchronisation. The only difference is that the received data does not get transferred to the RHR.

### 6.5.2 Line Control Register 'LCR'

The LCR specifies the data format that is common to both transmitter and receiver. Writing 0xBF to LCR enables access to the EFR, XON1, XOFF1, XON2 and XOFF2, DLL and DLM registers. This value (0xBF) corresponds to an unused data format. Writing the value 0xBF to LCR will set LCR[7] but leaves LCR[6:0] unchanged. Therefore, the data format of the transmitter and receiver data is not affected. Write the desired LCR value to exit from this selection.

LCR[1:0]: Data length

LCR[1:0] Determines the data length of serial characters. Note however, that these values are ignored in 9-bit data framing mode, i.e. when NMR[0] is set.

LCR[1:0]	Data length
00	5 bits
01	6 bits
10	7 bits
11	8 bits

Table 31: LCR Data Length Configuration

LCR[2]: Number of stop bits

LCR[2] defines the number of stop bits per serial character.

LCR[2]	Data length	No. stop bits

0	5,6,7,8	1
1	5	1.5
1	6,7,8	2

Table 32: LCR Stop Bit Number Configuration

LCR[5:3]: Parity type

The selected parity type will be generated during transmission and checked by the receiver, which may produce a parity error as a result. In 9-bit mode parity is disabled and LCR[5:3] is ignored.

LCR[5:3]	Parity type
xx0	No parity bit
001	Odd parity bit
011	Even parity bit
101	Parity bit forced to 1
111	Parity bit forced to 0

Table 33: LCR Parity Configuration

LCR[6]: Transmission break

logic 0 ⇒ Break transmission disabled.

logic 1 ⇒ Forces the transmitter data output SOUT low to alert the communication terminal, or send zeros in IrDA mode.

It is the responsibility of the software driver to ensure that the break duration is longer than the character period for it to be recognised remotely as a break rather than data.

LCR[7]: Divisor latch enable

logic 0 ⇒ Access to DLL and DLM registers disabled.

logic 1 ⇒ Access to DLL and DLM registers enabled.

### 6.5.3 Line Status Register 'LSR'

This register provides the status of data transfer to CPU.

LSR[0]: RHR data available

logic 0 ⇒ RHR is empty: no data available

logic 1 ⇒ RHR is not empty: data is available to be read.

LSR[1]: RHR overrun error

logic 0 ⇒ No overrun error.

logic 1 ⇒ Data was received when the RHR was full. An overrun error has occurred. The error is flagged when the data would normally have been transferred to the RHR.

**LSR[2]: Received data parity error**

logic 0 ⇒ No parity error in normal mode or 9<sup>th</sup> bit of received data is '0' in 9-bit mode.

logic 1 ⇒ Data has been received that did not have correct parity in normal mode or 9<sup>th</sup> bit of received data is '1' in 9-bit mode.

The flag will be set when the data item in error is at the top of the RHR and cleared following a read of the LSR. In 9-bit mode LSR[2] is no longer a flag and corresponds to the 9<sup>th</sup> bit of the received data in RHR.

**LSR[3]: Received data framing error**

logic 0 ⇒ No framing error.

logic 1 ⇒ Data has been received with an invalid stop bit.

This status bit is set and cleared in the same manner as LSR[2]. When a framing error occurs, the UART will try to re-synchronise by assuming that the error was due to sampling the start bit of the next data item.

**LSR[4]: Received break error**

logic 0 ⇒ No receiver break error.

logic 1 ⇒ The receiver received a break.

A break condition occurs when the SIN line goes low (normally signifying a start bit) and stays low throughout the start, data, parity and first stop bit. (Note that the SIN line is sampled at the bit rate). One zero character with associated break flag set will be transferred to the RHR

and the receiver will then wait until the SIN line returns high. The LSR[4] break flag will be set when this data item gets to the top of the RHR and it is cleared following a read of the LSR.

**LSR[5]: THR empty**

logic 0 ⇒ Transmitter FIFO (THR) is not empty.

logic 1 ⇒ Transmitter FIFO (THR) is empty.

**LSR[6]: Transmitter and THR empty**

logic 0 ⇒ The transmitter is not idle

logic 1 ⇒ THR is empty and the transmitter has completed the character in shift register and is in idle mode. (I.e. set whenever the transmitter shift register and the THR are both empty.)

**LSR[7]: Receiver data error**

logic 0 ⇒ Either there are no receiver data errors in the FIFO or it was cleared by an earlier read of LSR.

logic 1 ⇒ At least one parity error, framing error or break indication in the FIFO.

In 450 mode LSR[7] is permanently cleared, otherwise this bit will be set when an erroneous character is transferred from the receiver to the RHR. It is cleared when the LSR is read. Note that in 16C550 this bit is only cleared when all of the erroneous data are removed from the FIFO. In 9-bit data framing mode parity is permanently disabled, so this bit is not affected by LSR[2].

## 6.6 Interrupts & Sleep Mode

The serial interrupt on the OXCF950 is routed through to the OXCF950 interrupt control, regardless of MCR[3].

### 6.6.1 Interrupt Enable Register 'IER'

Serial channel interrupts are enabled using the Interrupt Enable Register ('IER').

**IER[0]: Receiver data available interrupt mask**

logic 0 ⇒ Disable the receiver ready interrupt.

logic 1 ⇒ Enable the receiver ready interrupt.

**IER[1]: Transmitter empty interrupt mask**

logic 0 ⇒ Disable the transmitter empty interrupt.

logic 1 ⇒ Enable the transmitter empty interrupt.

**IER[2]: Receiver status interrupt**

*Normal mode:*

logic 0 ⇒ Disable the receiver status interrupt.

logic 1 ⇒ Enable the receiver status interrupt.

*9-bit data mode:*

logic 0 ⇒ Disable receiver status and address bit interrupt.

logic 1 ⇒ Enable receiver status and address bit interrupt.

In 9-bit mode (i.e. when NMR[0] is set) reception of a character with the address-bit (9<sup>th</sup> bit) set can generate a level 1 interrupt if IER[2] is set.

**IER[3]: Modem status interrupt mask**

logic 0 ⇒ Disable the modem status interrupt.

logic 1 ⇒ Enable the modem status interrupt.

**IER[4]: Sleep mode**

logic 0 ⇒ Disable sleep mode.

logic 1 ⇒ Enable sleep mode whereby the internal clock of the channel is switched off.

Sleep mode is described in section 6.6.4.

**IER[5]: Special character interrupt mask or alternate sleep mode**

*9-bit data framing mode:*

logic 0 ⇒ Disable the special character receive interrupt.

logic 1 ⇒ Enable the special character receive interrupt.

In 9-bit data mode, The receiver can detect up to four special characters programmed in Special Character 1 to 4. When IER[5] is set, a level 5 interrupt is asserted when a match is detected.

*650/950 modes (non-9-bit data framing):*

logic 0 ⇒ Disable the special character receive interrupt.

logic 1 ⇒ Enable the special character receive interrupt.

In 16C650 compatible mode when the device is in Enhanced mode (EFR[4]=1), this bit enables the detection of special characters. It enables both the detection of XOFF characters (when in-band flow control is enabled via EFR[3:0]) and the detection of the XOFF2 special character (when enabled via EFR[5]).

*750 mode (non-9-bit data framing):*

logic 0 ⇒ Disable alternate sleep mode.

logic 1 ⇒ Enable alternate sleep mode whereby the internal clock of the channel is switched off.

In 16C750 compatible mode (i.e. non-Enhanced mode), this bit is used an alternate sleep mode and has the same effect as IER[4]. (See section 6.6.4)

**IER[6]: RTS interrupt mask**

logic 0 ⇒ Disable the RTS interrupt.

logic 1 ⇒ Enable the RTS interrupt.

This enable is only operative in Enhanced mode (EFR[4]=1). In non-Enhanced mode, RTS interrupt is permanently enabled.

**IER[7]: CTS interrupt mask**

logic 0 ⇒ Disable the CTS interrupt.

logic 1 ⇒ Enable the CTS interrupt.

This enable is only operative in Enhanced mode (EFR[4]=1). In non-Enhanced mode, CTS interrupt is permanently enabled.

**6.6.2 Interrupt Status Register 'ISR'**

The source of the highest priority interrupt pending is indicated by the contents of the Interrupt Status Register 'ISR'. There are nine sources of interrupt at six levels of priority (1 is the highest) as tabulated below:

Level	Interrupt source	ISR[5:0] <i>see note 3</i>
-	No interrupt pending <sup>1</sup>	000001
1	Receiver status error or Address-bit detected in 9-bit mode	000110
2a	Receiver data available	000100
2b	Receiver time-out	001100
3	Transmitter THR empty	000010
4	Modem status change	000000
5 <sup>2</sup>	In-band flow control XOFF or Special character (XOFF2) or Special character 1, 2, 3 or 4 or bit 9 set in 9-bit mode	010000
6 <sup>2</sup>	CTS or RTS change of state	100000

Table 34: Interrupt Status Identification Codes

- Note1: ISR[0] indicates whether any interrupts are pending.  
 Note2: Interrupts of priority levels 5 and 6 cannot occur unless the UART is in Enhanced mode.  
 Note3: ISR[5] is only used in 650 & 950 modes. In 750 mode, it is '0' when FIFO size is 16 and '1' when FIFO size is 128. In all other modes it is permanently set to '0'.

**6.6.3 Interrupt Description**

*Level 1:*

**Receiver status error interrupt (ISR[5:0]='000110'):**  
*Normal (non-9-bit) mode:*  
 This interrupt is active whenever any of LSR[1], LSR[2], LSR[3] or LSR[4] are set. These flags are cleared following a read of the LSR. This interrupt is masked with IER[2].

*9-bit mode:*  
 This interrupt is active whenever any of LSR[1], LSR[2], LSR[3] or LSR[4] are set. The receiver error interrupt due to LSR[1], LSR[3] and LSR[4] is masked with IER[3]. The 'address-bit' received interrupt is masked with NMR[1]. The software driver can differentiate between receiver status error and received address-bit (9<sup>th</sup> data bit) interrupt by examining LSR[1] and LSR[7]. In 9-bit mode LSR[7] is only set when LSR[3] or LSR[4] is set and it is not affected by LSR[2] (i.e. 9<sup>th</sup> data bit).

*Level 2a:*

**Receiver data available interrupt (ISR[5:0]='000100'):**  
 This interrupt is active whenever the receiver FIFO level is above the interrupt trigger level.

*Level 2b:*

**Receiver time-out interrupt (ISR[5:0]='001100'):**  
 A receiver time-out event, which may cause an interrupt, will occur when all of the following conditions are true:

- The UART is in a FIFO mode
- There is data in the RHR.
- There has been no read of the RHR for a period of time greater than the time-out period.
- There has been no new data received and written into the RHR for a period of time greater than the time-out period. The time-out period is four times the character period (including start and stop bits) measured from the centre of the first stop bit of the last data item received.

Reading the first data item in RHR clears this interrupt.

*Level 3:*

**Transmitter empty interrupt (ISR[5:0]='000010'):**  
 This interrupt is set when the transmit FIFO level falls below the trigger level. It is cleared on an ISR read of a level 3 interrupt or by writing more data to the THR so that the trigger level is exceeded. Note that when 950 mode trigger levels are enabled (ACR[5]=1) and the transmitter trigger level of zero is selected (TTL=0x00), a transmitter empty interrupt will only be asserted when both the transmitter FIFO and transmitter shift register are empty and the SOUT line has returned to idle marking state.

*Level 4:*

**Modem change interrupt (ISR[5:0]='000000'):**  
 This interrupt is set by a modem change flag (MSR[0], MSR[1], MSR[2] or MSR[3]) becoming active due to changes in the input modem lines. This interrupt is cleared following a read of the MSR.

*Level 5:*

**Receiver in-band flow control (XOFF) detect interrupt, Receiver special character (XOFF2) detect interrupt, Receiver special character 1, 2, 3 or 4 interrupt or 9<sup>th</sup> Bit set interrupt in 9-bit mode (ISR[5:0]='010000'):**  
 A level 5 interrupt can only occur in Enhanced-mode when any of the following conditions are met:

- A valid XOFF character is received while in-band flow control is enabled.
- A received character matches XOFF2 while special character detection is enabled.
- A received character matches special character 1, 2, 3 or 4 in 9-bit mode (see section 6.11.9).

It is cleared on an ISR read of a level 5 interrupt.



Level 6:

#### CTS or RTS changed interrupt (ISR[5:0]='100000'):

This interrupt is set whenever either of the CTS# or RTS# pins changes state from low to high. It is cleared on an ISR read of a level 6 interrupt.

#### 6.6.4 Sleep Mode

For a channel to go into sleep mode, all of the following conditions must be met:

- Sleep mode enabled (IER[4]=1 in 650/950 modes, or IER[5]=1 in 750 mode):
- The transmitter is idle, i.e. the transmitter shift register and FIFO are both empty.
- SIN is high.
- The receiver is idle.

### 6.7 Modem Interface

#### 6.7.1 Modem Control Register 'MCR'

##### MCR[0]: DTR

- logic 0 ⇒ Force DTR# output to inactive (high).
- logic 1 ⇒ Force DTR# output to active (low).

Note that DTR# can be used for automatic out-of-band flow control when enabled using ACR[4:3] (see section 6.11.3).

##### MCR[1]: RTS

- logic 0 ⇒ Force RTS# output to inactive (high).
- logic 1 ⇒ Force RTS# output to active (low).

Note that RTS# can be used for automatic out-of-band flow control when enabled using EFR[6] (see section 6.9.4).

##### MCR[2]: OUT1

- logic 0 ⇒ Force OUT1# output low when loopback mode is disabled.
- logic 1 ⇒ Force OUT1# output high.

OUT1# is not normally bonded out in the OXCF950 except in C950 mode, but is internally used for loopback testing

##### MCR[3]: OUT2

- logic 0 ⇒ Force OUT2# output low when loopback mode is disabled.
- logic 1 ⇒ Force OUT2# output high.

OUT2# is not normally bonded out in the OXCF950 except in C950 mode, but is internally used for loopback testing

##### MCR[4]: Loopback mode

- logic 0 ⇒ Normal operating mode.
- logic 1 ⇒ Enable local loop-back mode (diagnostics).

- The receiver FIFO is empty (LSR[0]=0).
- The UART is not in loopback mode (MCR[4]=0).
- Changes on modem input lines have been acknowledged (i.e. MSR[3:0]=0000).
- No interrupts are pending.

A read of IER[4] (or IER[5] if a 1 was written to that bit instead) shows whether the power-down request was successful. The UART will fully retain its programmed state whilst in power-down mode.

The channel will automatically exit power-down mode when any of the conditions 1 to 7 becomes false. It may be woken manually by clearing IER[4] (or IER[5] if the alternate sleep mode is enabled).

Sleep mode operation is not available in IrDA mode.

In local loop-back mode, the transmitter output (SOUT) and the modem outputs (DTR#, RTS#) are set in-active (high), and the receiver inputs SIN, CTS#, DSR#, DCD#, and RI# are all disabled. Internally the transmitter output is connected to the receiver input and DTR#, RTS#, OUT1# and OUT2# are connected to modem status inputs DSR#, CTS#, RI# and DCD# respectively.

In this mode, the receiver and transmitter interrupts are fully operational. The modem control interrupts are also operational, but the interrupt sources are now the lower four bits of the Modem Control Register instead of the four modem status inputs. The interrupts are still controlled by the IER.

MCR[5]: Enable XON-Any in Enhanced mode or enable out-of-band flow control in non-Enhanced mode

*650/950 modes (Enhanced mode):*

- logic 0 ⇒ XON-Any is disabled.
- logic 1 ⇒ XON-Any is enabled.

In enhanced mode (EFR[4]=1), this bit enables the Xon-Any operation. When Xon-Any is enabled, any received data will be accepted as a valid XON (see in-band flow control, section 6.9.3).

*750 mode (Non-Enhanced mode):*

- logic 0 ⇒ CTS/RTS flow control disabled.
- logic 1 ⇒ CTS/RTS flow control enabled.

In non-enhanced mode, this bit enables the CTS/RTS out-of-band flow control.

##### MCR[6]: IrDA mode

- logic 0 ⇒ Standard serial receiver and transmitter data format.

logic 1 ⇒ Data will be transmitted and received in IrDA format.

This function is only available in Enhanced mode. It requires a 16x clock to function correctly.

**MCR[7]: Baud rate prescaler select**

logic 0 ⇒ Normal (divide by 1) baud rate generator prescaler selected.

logic 1 ⇒ Divide-by-“M N/8” baud rate generator prescaler selected.

Where M & N are programmed in CPR (ICR offset 0x01). After a hardware reset, CPR defaults to 0x20 (divide-by-4) and MCR[7] is reset to ‘0’. User writes to this flag will only take effect in enhanced mode. See section 6.9.1.

**6.7.2 Modem Status Register ‘MSR’**

**MSR[0]: Delta CTS#**

Indicates that the CTS# input has changed since the last time the MSR was read.

**MSR[1]: Delta DSR#**

Indicates that the DSR# input has changed since the last time the MSR was read.

**MSR[2]: Trailing edge RI#**

Indicates that the RI# input has changed from low to high since the last time the MSR was read.

**MSR[3]: Delta DCD#**

Indicates that the DCD# input has changed since the last time the MSR was read.

**MSR[4]: CTS**

This bit is the complement of the CTS# input. It is equivalent to RTS (MCR[1]) during internal loop-back mode.

**MSR[5]: DSR**

This bit is the complement of the DSR# input. It is equivalent to DTR (MCR[0]) during internal loop-back mode.

**MSR[6]: RI**

This bit is the complement of the RI# input. In internal loop-back mode it is equivalent to the internal OUT1.

**MSR[7]: DCD**

This bit is the complement of the DCD# input. In internal loop-back mode it is equivalent to the internal OUT2.

**6.8 Other Standard Registers**

**6.8.1 Divisor Latch Registers ‘DLL & DLM’**

The divisor latch registers are used to program the baud rate divisor. This is a value between 1 and 65535 by which the input clock is divided by in order to generate serial baud rates. After a hardware reset, the baud rate used by the transmitter and receiver is given by:

$$Baudrate = \frac{InputClock}{16 * Divisor}$$

Where divisor is given by DLL + ( 256 x DLM ). More flexible baud rate generation options are also available. See section 6.10 for full details.

**6.8.2 Scratch Pad Register ‘SPR’**

The scratch pad register does not affect operation of the rest of the UART in any way and can be used for temporary data storage. The register may also be used to define an offset value to access the registers in the Indexed Control Register set. For more information on Indexed Control registers see Table 27 and section 6.11.

**6.9 Automatic Flow Control**

Automatic in-band flow control, automatic out-of-band flow control and special character detection features can be used when in Enhanced mode and are software compatible with the 16C654. Alternatively, 16C750 compatible automatic out-of-band flow control can be enabled when in non-Enhanced mode. In 950 mode, in-band and out-of-band flow controls are compatible with 16C654, with the addition of fully programmable flow control thresholds.

**6.9.1 Enhanced Features Register ‘EFR’**

Writing 0xBF to LCR enables access to the EFR and other Enhanced mode registers. This value corresponds to an unused data format. Writing 0xBF to LCR will set LCR[7] but leaves LCR[6:0] unchanged. Therefore, the data format of the transmitter and receiver data is not affected. Write the desired LCR value to exit from this selection.

Note: In-band transmit and receive flow control is disabled in 9-bit mode.

#### EFR[1:0]: In-band receive flow control mode

When in-band receive flow control is enabled, the UART compares the received data with the programmed XOFF character(s). When this occurs, the UART will disable transmission as soon as any current character transmission is complete. The UART then compares the received data with the programmed XON character(s). When a match occurs, the UART will re-enable transmission (see section 6.11.6).

For automatic in-band flow control, bit 4 of EFR must be set. The combinations of software receive flow control can be selected by programming EFR[1:0] as follows:

- logic [00] ⇒ In-band receive flow control is disabled.
- logic [01] ⇒ Single character in-band receive flow control enabled, recognising XON2 as the XON character and XOFF2 as the XOFF character.
- logic [10] ⇒ Single character in-band receive flow control enabled, recognising XON1 as the XON character and XOFF1 and the XOFF character.
- logic [11] ⇒ The behaviour of the receive flow control is dependent on the configuration of EFR[3:2]. single character in-band receive flow control is enabled, accepting both XON1 and XON2 as valid XON characters and both XOFF1 and XOFF2 as valid XOFF characters when EFR[3:2] = "01" or "10". EFR[1:0] should not be set to "11" when EFR[3:2] is either "00".

#### EFR[3:2]: In-band transmit flow control mode

When in-band transmit flow control is enabled, XON/XOFF characters are inserted into the data stream whenever the RFL passes the upper trigger level and falls below the lower trigger level respectively.

For automatic in-band flow control, bit 4 of EFR must be set. The combinations of software transmit flow control can then be selected by programming EFR[3:2] as follows:

- logic [00] ⇒ In-band transmit flow control is disabled.
- logic [01] ⇒ Single character in-band transmit flow control enabled, using XON2 as the XON character and XOFF2 as the XOFF character.
- logic [10] ⇒ Single character in-band transmit flow control enabled, using XON1 as the XON character and XOFF1 as the XOFF character.
- Logic[11] ⇒ The value EFR[3:2] = "11" is reserved for future use and should not be used

#### EFR[4]: Enhanced mode

- logic 0 ⇒ Non-Enhanced mode. Disables IER bits 4-7, ISR bits 4-5, FCR bits 4-5, MCR bits 5-7 and in-band flow control. Whenever this bit is cleared, the setting of other bits of EFR are ignored.
- logic 1 ⇒ Enhanced mode. Enables the Enhanced Mode functions. These functions include enabling IER bits 4-7, FCR bits 4-5, MCR bits 5-7. For in-band flow control the software driver must set this bit first. If this bit is set, out-of-band flow control is configured with EFR bits 6-7, otherwise out-of-band flow control is compatible with 16C750.

#### EFR[5]: Enable special character detection

- logic 0 ⇒ Special character detection is disabled.
- logic 1 ⇒ While in Enhanced mode (EFR[4]=1), the UART compares the incoming receiver data with the XOFF2 value. Upon a correct match, the received data will be transferred to the RHR and a level 5 interrupt (XOFF or special character) will be asserted if level 5 interrupts are enabled (IER[5] set to 1).

#### EFR[6]: Enable automatic RTS flow control.

- logic 0 ⇒ RTS flow control is disabled (default).
- logic 1 ⇒ RTS flow control is enabled in Enhanced mode (i.e. EFR[4] = 1), where the RTS# pin will be forced inactive high if the RFL reaches the upper flow control threshold. This will be released when the RFL drops below the lower threshold. The 650 and 950 software drivers should use this bit to enable RTS flow control. The 750 compatible driver uses MCR[5] to enable RTS flow control.

#### EFR[7]: Enable automatic CTS flow control.

- logic 0 ⇒ CTS flow control is disabled (default).
- logic 1 ⇒ CTS flow control is enabled in Enhanced mode (i.e. EFR[4] = 1), where the data transmission is prevented whenever the CTS# pin is held inactive high. The 650 and 950 software drivers should use this bit to enable CTS flow control. The 750 compatible driver uses MCR[5] to enable CTS flow control.

### 6.9.2 Special Character Detection

In Enhanced mode (EFR[4]=1), when special character detection is enabled (EFR[5]=1) and the receiver matches received data with XOFF2, the 'received special character' flag ASR[4] will be set and a level 5 interrupt is asserted, (if enabled by IER[5]). This flag will be cleared following a read of ASR. The received status (i.e. parity and framing) of special characters does not have to be valid for these characters to be accepted as valid matches.

**6.9.3 Automatic In-band Flow Control**

When in-band receive flow control is enabled, the UART will compare the received data with XOFF1 or XOFF2 characters to detect an XOFF condition. When this occurs, the UART will disable transmission as soon as any current character transmission is complete. Status bits ISR[4] and ASR[0] will be set. A level 5 interrupt will occur if enabled by IER[5]. The UART will then compare all received data with XON1 or XON2 characters to detect an XON condition. When this occurs, the UART will re-enable transmission and status bits ISR[4] and ASR[0] will be cleared.

Any valid XON/XOFF characters will not be written into the RHR. An exception to this rule occurs if special character detection is enabled and an XOFF2 character is received that is a valid XOFF. In this instance, the character will be written into the RHR.

The received status (i.e. parity and framing) of XON/XOFF characters does not have to be valid for these characters to be accepted as valid matches.

When the 'XON Any' flag (MCR[5]) is set, any received character is accepted as a valid XON condition and the transmitter will be re-enabled. The received data will be transferred to the RHR.

When in-band transmit flow control is enabled, the RFL will be sampled whenever the transmitter is idle (briefly, between characters, or when the THR is empty) and an XON/XOFF character may be inserted into the data stream if needed. Initially, remote transmissions are enabled and hence ASR[1] is clear. If ASR[1] is clear and the RFL has passed the upper trigger level (i.e. is above the trigger level), XOFF will be sent and ASR[1] will be set. If ASR[1]

is set and the RFL falls below the lower trigger level, XON will be sent and ASR[1] will be cleared.

If transmit flow control is disabled after an XOFF has been sent, an XON will be sent automatically.

**6.9.4 Automatic Out-of-band Flow Control**

Automatic RTS/CTS flow control is selected by different means, depending on whether the UART is in Enhanced or non-Enhanced mode. When in non-Enhanced mode, MCR[5] enables both RTS and CTS flow control. When in Enhanced mode, EFR[6] enables automatic RTS flow control and EFR[7] enables automatic CTS flow control. This allows software compatibility with both 16C650 and 16C750 drivers.

When automatic CTS flow control is enabled and the CTS# input becomes active, the UART will disable transmission as soon as any current character transmission is complete. Transmission is resumed whenever the CTS# input becomes inactive.

When automatic RTS flow control is enabled, the RTS# pin will be forced inactive when the RFL reaches the upper trigger level and will return to active when the RFL falls below the lower trigger level. The automatic RTS# flow control is ANDed with MCR[1] and hence is only operational when MCR[1]=1. This allows the software driver to override the automatic flow control and disable the remote transmitter regardless by setting MCR[1]=0 at any time.

Automatic DTR/DSR flow control behaves in the same manner as RTS/CTS flow control but is enabled by ACR[3:2], regardless of whether or not the UART is in Enhanced mode.

**6.10 Baud Rate Generation**

**6.10.1 General Operation**

The UART contains a programmable baud rate generator that is capable of taking any clock input from DC to 60MHz and dividing it by any 16-bit divisor number from 1 to 65535 written into the DLM (MSB) and DLL (LSB) registers. In addition to this, a clock prescaler register is provided which can further divide the clock by values in the range 1.0 to 31.875 in steps of 0.125. Also, a further feature is the Times Clock Register 'TCR' which allows the sampling clock to be set to any value between 4 and 16.

These clock options allow for highly flexible baud rate generation capabilities from almost any input clock frequency (up to 60MHz). The actual transmitter and receiver baud rate is calculated as follows:

$$BaudRate = \frac{InputClock}{SC * Divisor * prescaler}$$

Where:

- SC = Sample clock values defined in TCR[3:0]
- Divisor = DLL + ( 256 x DLM )
- Prescaler = 1 when MCR[7] = '0' else:  
= M + ( N / 8 ) where:
- M = CPR[7:3] (Integer part – 1 to 31)
- N = CPR[2:0] (Fractional part – 0.000 to 0.875 )

See next section for a discussion of the clock prescaler and times clock register.

After a hardware reset, the prescaler is bypassed (set to 1) and TCR is set to 0x00 (i.e. SC = 16). Assuming this default configuration, the following table gives the divisors required to be programmed into the DLL and DLM registers in order to obtain various standard baud rates:

DLM:DLL Divisor Word	Baud Rate (bits per second)
0x0900	50
0x0300	110
0x0180	300
0x00C0	600
0x0060	1,200
0x0030	2,400
0x0018	4,800
0x000C	9,600
0x0006	19,200
0x0004	28,800
0x0003	38,400
0x0002	57,600
0x0001	115,200

Table 35: Standard PC COM Port Baud Rate Divisors (assuming a 1.8432MHz crystal)

### 6.10.2 Clock Prescaler Register 'CPR'

The CPR register is located at offset 0x01 of the ICR

The prescaler divides the system clock by any value in the range of 1 to "31 7/8" in steps of 1/8. The divisor takes the form "M + N/8", where M is the 5 bit value defined in CPR[7:3] and N is the 3 bit value defined in CPR[2:0].

The prescaler is by-passed and a prescaler value of '1' is selected by default when MCR[7] = 0.

MCR[7] is reset to '0' after a hardware reset but may be overwritten by software. Note however that since access to MCR[7] is restricted to Enhanced mode only, EFR[4] should first be set and then MCR[7] set or cleared as required.

If MCR[7] is set by software, the internal clock prescaler is enabled.

Upon a hardware reset, CPR defaults to 0x20 (division-by-4). Compatibility with existing 16C550 baud rate divisors is maintained using a 1.8432MHz clock.

For higher baud rates use a higher frequency clock, e.g. 14.7456MHz, 18.432MHz, 32MHz, 40MHz or 60.0MHz. The flexible prescaler allows system designers to generate popular baud rates using clocks that are not integer multiples of the required rate. When using a non-standard clock frequency, compatibility with existing 16C550

software drivers may be maintained with a minor software patch to program the on-board prescaler to divide the high frequency clock down to 1.8432MHz.

Table 37 on the following page gives the prescaler values required to operate the UARTs at compatible baud rates with various different crystal frequencies. Also given is the maximum available baud rates in TCR = 16 and TCR = 4 modes with CPR = 1.

### 6.10.3 Times Clock Register 'TCR'

The TCR register is located at offset 0x02 of the ICR

The 16C550 and other compatible devices such as 16C650 and 16C750 use a 16 times (16x) over-sampling channel clock. The 16x over-sampling clock means that the channel clock runs at 16 times the selected serial bit rate. It limits the highest baud rate to 1/16 of the system clock when using a divisor latch value of unity. However, the 950 UART is designed in a manner to enable it to accept other multiplications of the bit rate clock. It can use values from 4x to 16x clock as programmed in the TCR as long as the clock (oscillator) frequency error, stability and jitter are within reasonable parameters. Upon hardware reset the TCR is reset to 0x00 which means that a 16x clock will be used, for compatibility with the 16C550 and compatibles.

The maximum baud-rates available for various system clock frequencies at all of the allowable values of TCR are indicated in Table 38 on the following page. These are the values in bits-per-second (bps) that are obtained if the divisor latch = 0x01 and the Prescaler is set to 1.

The OXCF950 has the facility to operate at baud-rates up to 15 Mbps.

The table below indicates how the value in the register corresponds to the number of clock cycles per bit. TCR[3:0] is used to program the clock. TCR[7:4] are unused and will return "0000" if read.

TCR[3:0]	Clock cycles per bit
0000 to 0011	16
0100 to 1111	4-15

Table 36: TCR Sample Clock Configuration

The use of TCR does not require the device to be in 650 or 950 mode although only drivers that have been written to take advantage of the 950 mode features will be able to access this register. Writing 0x01 to the TCR will not switch the device into 1x isochronous mode, this is explained in the following section. (TCR has no effect in isochronous mode). If 0x01, 0x10 or 0x11 is written to TCR the device will operate in 16x mode.

Reading TCR will always return the last value that was written to it irrespective of mode of operation.

Clock Frequency (MHz)	CPR value	Effective crystal frequency	Error from 1.8432MHz (%)	Max. Baud rate with CPR = 1, TCR = 16	Max. Baud rate with CPR = 1, TCR = 4
1.8432	0x08 (1.000)	1.8432	0.00	115,200	460,800
7.3728	0x20(4.000)	1.8432	0.00	460,800	1,843,200
14.7456	0x40 (8.000)	1.8432	0.00	921,600	3,686,400
18.432	0x50 (10.000)	1.8432	0.00	1,152,000	4,608,000
32.000	0x8B(17.375)	1.8417	0.08	2,000,000	8,000,000
33.000	0x8F (17.875)	1.8462	0.16	2,062,500	8,250,000
40.000	0xAE (21.750)	1.8391	0.22	2,500,000	10,000,000
50.000	0xD9 (27.125)	1.8433	0.01	3,125,000	12,500,000
60.000*	0xFF (31.875)	1.8824	2.13	3,750,000	15,000,000

Table 37: Example clock options and their associated maximum baud rates

Sampling Clock	TCR Value	System Clock (MHz)							
		1.8432	7.372	14.7456	18.432	32	40	50	60
16	0x00	115,200	460,750	921,600	1.152M	2.00M	2.50M	3.125M	3.75M
15	0x0F	122,880	491,467	983,040	1,228,800	2,133,333	2,666,667	3,333,333	4.00M
14	0x0E	131,657	526,571	1,053,257	1,316,571	2,285,714	2,857,143	3,571,429	4,285,714
13	0x0D	141,785	567,077	1,134,277	1,417,846	2,461,538	3,076,923	3,846,154	4,615,384
12	0x0C	153,600	614,333	1,228,800	1,536,000	2,666,667	3,333,333	4,166,667	5.00M
11	0x0B	167,564	670,182	1,340,509	1,675,636	2,909,091	3,636,364	4,545,455	5,454,545
10	0x0A	184,320	737,200	1,474,560	1,843,200	3.20M	4.00M	5.00M	6.00M
9	0x09	204,800	819,111	1,638,400	2,048,000	3,555,556	4,444,444	5,555,556	6,666,667
8	0x08	230,400	921,500	1,843,200	2,304,000	4.00M	5.00M	6.25M	7.50M
7	0x07	263,314	1,053,143	2,106,514	2,633,143	4,571,429	5,714,286	7,142,857	8,571,428
6	0x06	307,200	1,228,667	2,457,600	3,072,000	5,333,333	6,666,667	8,333,333	10.00M
5	0x05	368,640	1,474,400	2,949,120	3,686,400	6.40M	8.00M	10.00M	12.00M
4	0x04	460,800	1,843,000	3,686,400	4,608,000	8.00M	10.00M	12.50M	15.00M

Table 38: Maximum Baud Rates Available at all 'TCR' Sampling Clock Values

### 6.10.4 Input Clock Options

A system clock must be applied to XTLI pin on the device. The speed of this clock determines the maximum baud rate at which the device can receive and transmit serial data. This maximum is equal to one sixteenth of the frequency of the system clock (Increasing to one quarter of this value if TCR=4 is used).

The industry standard system clock for PC COM ports is 1.8432 MHz, limiting the maximum baud rate to 115.2 Kbps. The OXCF950 supports system clocks up to 60MHz and its flexible baud rate generation hardware means that almost any frequency can be optionally scaled down for compatibility with standard devices.

Designers have the option of using either TTL clock modules or crystal oscillator circuits for system clock input, with minimal additional components. The following two sections describe how each can be connected. Note restrictions on the maximum clock frequency may apply when an external EEPROM is being used. The designer must ensure the clock frequency/64 is within the external EEPROM's allowed range.

### 6.10.5 TTL Clock Module

Using a TTL module for the system clock simply requires the module to be supplied with +3V3 power and GND connections. The clock output can then be connected directly to XTLI. XTLO should be left unconnected. Note that the XTLI input on the OXCF950 is not 5V tolerant.

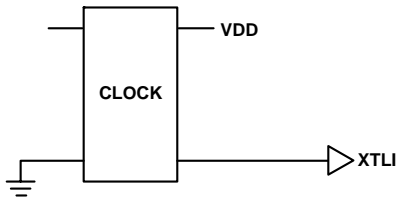

Figure 6: Clock Module Connectivity

**6.10.6 External 1x Clock Mode**

The transmitter and receiver can accept an external clock applied to the RI# and DSR# pins respectively. The clock options are selected using the clock select register (CKS - see section 6.11.8). The transmitter and receiver may be configured to operate in 1x (Isochronous) mode by setting CKS[7] and CKS[3], respectively. In Isochronous mode, transmitter or receiver will use the 1x clock (usually but not necessarily an external source) where asynchronous framing is maintained using start, parity and stop-bits. However serial transmission and reception is synchronised to the 1x clock. In this mode asynchronous data may be transmitted at baud rates up to 60Mbps. The local 1x clock source can be asserted on the DTR# pin.

Note that line drivers need to be capable of transmission at data rates twice the system clock used (as one cycle of the system clock corresponds to 1 bit of serial data). Also note that enabling modem interrupts is illegal in isochronous mode, as the clock signal will cause a continuous change to the modem status (unless masked in MDM register, see section 6.11.10).

**6.11 Additional Features**

**6.11.1 Additional Status Register 'ASR'**

**ASR[0]: Transmitter disabled**

- logic 0 ⇒ The transmitter is not disabled by in-band flow control.
- logic 1 ⇒ The receiver has detected an XOFF, and has disabled the transmitter.

This bit is cleared after a hardware reset or channel software reset. The software driver may write a 0 to this bit to re-enable the transmitter if it was disabled by in-band flow control. Writing a 1 to this bit has no effect.

**ASR[1]: Remote transmitter disabled**

- logic 0 ⇒ The remote transmitter is not disabled by in-band flow control.
- logic 1 ⇒ The transmitter has sent an XOFF character, to disable the remote transmitter. (Cleared when a subsequent XON is sent).

**6.10.7 Crystal Oscillator Circuit**

The OXCF950 may be clocked by a crystal connected to XTLO and XTLO or directly from a clock source connected to the XTLO pin. The circuit required to use the on-chip oscillator is shown below. Note the crystal circuit is only suitable for operation up to 20 MHz.

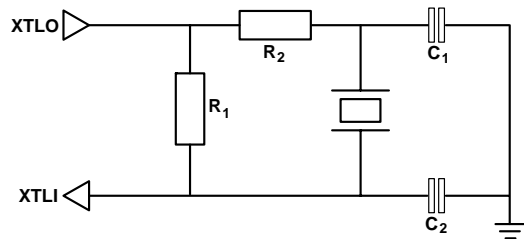

Figure 7: Crystal Oscillator Circuit

Frequency Range (MHz)	C1 (pF)	C2 (pF)	R1 (Ω)	R2 (Ω)
1.8432 – 8	68	22	220K	470R
8-20	33-68	33 – 68	220K-2M2	470R

Table 39: Component Values

Note: For better stability use a smaller value of R1. Increase R1 to reduce power consumption. The total capacitive load (C1 in series with C2) should be that specified by the crystal manufacturer (nominally 16pF)

This bit is cleared after a hardware reset or channel software reset. The software driver may write a 0 to this bit to re-enable the remote transmitter (an XON is transmitted). Writing a 1 to this bit has no effect.

Note: The remaining bits (ASR[7:2]) of this register are read only

**ASR[2]: RTS**

This is the complement of the actual state of the RTS# pin when the device is not in loopback mode. The driver software can determine if the remote transmitter is disabled by RTS# out-of-band flow control by reading this bit. In loopback mode this bit reflects the flow control status rather than the pin's actual state.

**ASR[3]: DTR**

This is the complement of the actual state of the DTR# pin when the device is not in loopback mode. The driver software can determine if the remote transmitter is disabled by DTR# out-of-band flow control by reading this bit. In loopback mode this bit reflects the flow control status rather than the pin's actual state.

**ASR[4]: Special character detected**

logic 0 ⇒ No special character has been detected.  
 logic 1 ⇒ A special character has been received and is stored in the RHR.

This can be used to determine whether a level 5 interrupt was caused by receiving a special character rather than an XOFF. The flag is cleared following the read of the ASR.

**ASR[5]: RESERVED**

This bit is unused in the OXCF950 and reads '0'.

**ASR[6]: FIFO size**

logic 0 ⇒ FIFOs are 16 deep if FCR[0] = 1.  
 logic 1 ⇒ FIFOs are 128 deep if FCR[0] = 1.

Note: If FCR[0] = 0, the FIFOs are 1 deep.

**ASR[7]: Transmitter Idle**

logic 0 ⇒ Transmitter is transmitting.  
 logic 1 ⇒ Transmitter is idle.

This bit reflects the state of the internal transmitter. It is set when both the transmitter FIFO and shift register are empty.

**6.11.2 FIFO Fill levels 'TFL & RFL'**

The number of characters stored in the THR and RHR can be determined by reading the TFL and RFL registers respectively. As the UART clock is asynchronous with respect to the processor, it is possible for the levels to change during a read of these FIFO levels. It is therefore recommended that the levels are read twice and compared to check that the values obtained are valid. The values should be interpreted as follows:

1. The number of characters in the THR is no greater than the value read back from TFL.
2. The number of characters in the RHR is no less than the value read back from RFL.

**6.11.3 Additional Control Register 'ACR'**

The ACR register is located at offset 0x00 of the ICR

**ACR[0]: Receiver disable**

logic 0 ⇒ The receiver is enabled, receiving data and storing it in the RHR.

logic 1 ⇒ The receiver is disabled. The receiver continues to operate as normal to maintain the framing synchronisation with the receive data stream but received data is not stored into the RHR. In-band flow control characters continue

to be detected and acted upon. Special characters will not be detected.

Changes to this bit will only be recognised following the completion of any data reception pending.

**ACR[1]: Transmitter disable**

logic 0 ⇒ The transmitter is enabled, transmitting any data in the THR.

logic 1 ⇒ The transmitter is disabled. Any data in the THR is not transmitted but is held. However, in-band flow control characters may still be transmitted.

Changes to this bit will only be recognised following the completion of any data transmission pending.

**ACR[2]: Enable automatic DSR flow control**

logic 0 ⇒ Normal. The state of the DSR# line does not affect the flow control.

logic 1 ⇒ Data transmission is prevented whenever the DSR# pin is held inactive high.

This bit provides another automatic out-of-band flow control facility using the DSR# line.

**ACR[4:3]: DTR# line configuration**

When bits 4 or 5 of CKS (offset 0x03 of ICR) are set, the transmitter 1x clock or the output of the baud rate generator (Nx clock) are asserted on the DTR# pin, otherwise the DTR# pin is defined as follows:

logic [00] ⇒ DTR# is compatible with 16C450, 16C550, 16C650 and 16C750 (i.e. normal).

logic [01] ⇒ DTR# pin is used for out-of-band flow control. It will be forced inactive high if the Receiver FIFO Level ('RFL') reaches the upper flow control threshold. DTR# line will be re-activated when the RFL drops below the lower threshold (see FCL & FCH).

logic [10] ⇒ DTR# pin is configured to drive the active low enable pin of an external RS485 buffer. In this configuration the DTR# pin will be forced low whenever the transmitter is not empty (LSR[6]=0), otherwise DTR# pin is high.

logic [11] ⇒ DTR# pin is configured to drive the active-high enable pin of an external RS485 buffer. In this configuration, the DTR# pin will be forced high whenever the transmitter is not empty (LSR[6]=0), otherwise DTR# pin is low.

If the user sets ACR[4], then the DTR# line is controlled by the status of the transmitter empty bit of LCR. When ACR[4] is set, ACR[3] is used to select active high or active



low enable signals. In half-duplex systems using RS485 protocol, this facility enables the DTR# line to directly control the enable signal of external 3-state line driver buffers. When the transmitter is empty the DTR# would go inactive once the SOUT line returns to its idle marking state.

#### ACR[5]: 950 mode trigger levels enable

- logic 0 ⇒ Interrupts and flow control trigger levels are as described in FCR register and are compatible with 16C650/16C750 modes.
- logic 1 ⇒ 950 specific enhanced interrupt and flow control trigger levels defined by RTL, TTL, FCL and FCH are enabled.

#### ACR[6]: ICR read enable

- logic 0 ⇒ The Line Status Register is readable.
- logic 1 ⇒ The Indexed Control Registers are readable.

Setting this bit will map the ICR set to the LSR location for reads. During normal operation this bit should be cleared.

#### ACR[7]: Additional status enable

- logic 0 ⇒ Access to the ASR, TFL and RFL registers is disabled.
- logic 1 ⇒ Access to the ASR, TFL and RFL registers is enabled.

When ACR[7] is set, the MCR and LCR registers are no longer readable but remain writable, and the TFL and RFL registers replace them in the memory map for read operations. The IER register is replaced by the ASR register for all operations. The software driver may leave this bit set during normal operation, since MCR, LCR and IER do not generally need to be read.

### 6.11.4 Transmitter Trigger Level 'TTL'

The TTL register is located at offset 0x04 of the ICR

Whenever 950 trigger levels are enabled (ACR[5]=1), bits 4 and 5 of FCR are ignored and an alternative arbitrary transmitter interrupt trigger level can be defined in the TTL register. This 7-bit value provides a fully programmable transmitter interrupt trigger facility. In 950 mode, a priority level 3 interrupt occurs indicating that the transmitter buffer requires more characters when the interrupt is not masked (IER[1]=1) and the transmitter FIFO level falls below the value stored in the TTL register. The value 0 (0x00) has a special meaning. In 950 mode when the user writes 0x00 to the TTL register, a level 3 interrupt only occurs when the FIFO and the transmitter shift register are both empty and the SOUT line is in the idle marking state. This feature is particularly useful to report back the empty state of the transmitter after its FIFO has been flushed away.

### 6.11.5 Receiver Interrupt Trigger Level 'RTL'

The RTL register is located at offset 0x05 of the ICR

Whenever 950 trigger levels are enabled (ACR[5]=1), bits 6 and 7 of FCR are ignored and an alternative arbitrary receiver interrupt trigger level can be defined in the RTL register. This 7-bit value provides a fully programmable receiver interrupt trigger facility as opposed to the limited trigger levels available in 16C650 and 16C750 devices. It enables the system designer to optimise the interrupt performance hence minimising the interrupt overhead.

In 950 mode, a priority level 2 interrupt occurs indicating that the receiver data is available when the interrupt is not masked (IER[0]=1) and the receiver FIFO level reaches the value stored in this register.

### 6.11.6 Flow Control Levels 'FCL & FCH'

The FCL and FCH registers are located at offsets 0x06 and 0x07 of the ICR respectively

Enhanced software flow control using XON/XOFF and hardware flow control using RTS#/CTS# and DTR#/DSR# are available when 950 mode trigger levels are enabled (ACR[5]=1). Improved flow control threshold levels are offered using Flow Control Lower trigger level ('FCL') and Flow Control Higher trigger level ('FCH') registers to provide a greater degree of flexibility when optimising the flow control performance. Generally, these facilities are only available in Enhanced mode.

In 650 mode, in-band flow control is enabled using the EFR register. An XOFF character is transmitted when the receiver FIFO exceeds the upper trigger level defined by FCR[7:6] as described in section 6.4.1. An XON is then sent when the FIFO is read down to the lower fill level. The flow control is enabled and the appropriate mode selected using EFR[3:0].

In 950 mode, the flow control thresholds defined by FCR[7:6] are ignored. In this mode threshold levels are programmed using FCL and FCH. When in-band flow control is enabled (defined by EFR[3:0]) and the receiver FIFO level ('RFL') reaches the value programmed in the FCH register, an XOFF is transmitted to stop the flow of serial data. The flow is resumed when the receiver FIFO fill level falls to below the value programmed in the FCL register, at which point an XON character is sent. The FCL value of 0x00 is illegal.

For example if FCL and FCH contain 64 and 100 respectively, XOFF is transmitted when the receiver FIFO contains 100 characters, and XON is transmitted when sufficient characters are read from the receiver FIFO such that there are 63 characters remaining.

CTS/RTS and DSR/DTR out-of-band flow control use the same trigger levels as in-band flow control. When out-of-band flow control is enabled, RTS# (or DTR#) line is de-asserted when the receiver FIFO level reaches the upper limit defined in the FCH and is re-asserted when the receiver FIFO is drained below the lower limit defined in FCL. When 950 trigger levels are enabled (ACR[5]=1), the CTS# flow control functions as in 650 mode and is configured by EFR[7]. However, when EFR[6] is set, RTS# is automatically de-asserted when RFL reaches FCH and re-asserted when RFL drops below FCL.

DSR# flow control is configured with ACR[2]. DTR# flow control is configured with ACR[4:3].

### 6.11.7 Device Identification Registers

The identification registers is located at offsets 0x08 to 0x0B of the ICR

The 950 offers four bytes of device identification. The device ID registers may be read using offset values 0x08 to 0x0B of the Indexed Control Register. Registers ID1, ID2 and ID3 identify the device as an OX16C950 type and return 0x16, 0xC9 and 0x50 respectively. The REV register resides at offset 0x0B of ICR and identifies the revision of 950 core. This register returns 0x08 for the OXCF950 rev B.

### 6.11.8 Clock Select Register 'CKS'

The CKS register is located at offset 0x03 of the ICR

This register is cleared to 0x00 after a hardware reset to maintain compatibility with 16C550, but is unaffected by software reset. This allows the user to select a clock source and then reset the channel to work-around any timing glitches.

**CKS[1:0]: Receiver Clock Source Selector**

- logic [00] ⇒ The output of baud rate generator (internal BDOOUT#) is selected for the receiver clock.
- logic [01] ⇒ The DSR# pin is selected for the receiver clock.
- logic [10] ⇒ The output of baud rate generator (internal BDOOUT#) is selected for the receiver clock.
- logic [11] ⇒ The transmitter clock is selected for the receiver. This allows RI# to be used for both transmitter and receiver.

**CKS[2]: Reserved**

This bit is unused in the OXCF950 and should be written with '0'.

**CKS[3]: Receiver 1x clock mode selector**

- logic 0 ⇒ The receiver is in Nx clock mode as defined in the TCR register. After a hardware reset the receiver operates in 16x clock mode, i.e. 16C550 compatibility.
- logic 1 ⇒ The receiver is in isochronous 1x clock mode.

**CKS[5:4]: Transmitter 1x clock or baud rate generator output (BDOUT) on DTR# pin**

- logic [00] ⇒ The function of the DTR# pin is defined by the setting of ACR[4:3].
- logic [01] ⇒ The transmitter 1x clock (bit rate clock) is asserted on the DTR# pin and the setting of ACR[4:3] is ignored.
- logic [10] ⇒ The output of baud rate generator (Nx clock) is asserted on the DTR# pin and the setting of ACR[4:3] is ignored.
- logic [11] ⇒ Reserved.

**CKS[6]: Transmitter clock source selector**

- logic 0 ⇒ The transmitter clock source is the output of the baud rate generator (550 compatibility).
- logic 1 ⇒ The transmitter uses an external clock applied to the RI# pin.

**CKS[7]: Transmitter 1x clock mode selector**

- logic 0 ⇒ The transmitter is in Nx clock mode as defined in the TCR register. After a hardware reset the transmitter operates in 16x clock mode, i.e. 16C550 compatibility.
- logic 1 ⇒ The transmitter is in isochronous 1x clock mode.

### 6.11.9 Nine-bit Mode Register 'NMR'

The NMR register is located at offset 0x0D of the ICR

The 950 offers 9-bit data framing for industrial multi-drop applications. 9-bit mode is enabled by setting bit 0 of the Nine-bit Mode Register (NMR). In 9-bit mode the data length setting in LCR[1:0] is ignored. Furthermore as parity is permanently disabled, the setting of LCR[5:3] is also ignored.

The receiver stores the 9th bit of the received data in LSR[2] (where parity error is stored in normal mode). Note that the 950 provides a 128-deep FIFO for LSR[3:1]. The transmitter FIFO is 9-bit wide and 128 deep. The user should write the 9th (MSB) data bit in SPR[0] first and then write the other 8 bits to THR.

As parity mode is disabled, LSR[7] is set whenever there is an overrun, framing error or received break condition. It is unaffected by the contents of LSR[2] (Now the received 9th data bit).

In 9-bit mode, in-band flow control is disabled regardless of the setting of EFR[3:0] and the XON1/XON2/XOFF1 and XOFF2 registers are used for special character detection.

*Interrupts in 9-Bit Mode:*

While IER[2] is set, upon receiving a character with status error, a level 1 interrupt is asserted when the character and the associated status are transferred to the FIFO.

The 950 can assert an optional interrupt if a received character has its 9<sup>th</sup> bit set. As multi-drop systems often use the 9<sup>th</sup> bit as an address bit, the receiver is able to generate an interrupt upon receiving an address character. This feature is enabled by setting NMR[2]. This will result in a level 1 interrupt being asserted when the address character is transferred to the receiver FIFO.

In this case, as long as there are no errors pending, i.e. LSR[1], LSR[3], and LSR[4] are clear, '0' can be read back from LSR[7] and LSR[1], thus differentiating between an 'address' interrupt and receiver error or overrun interrupt in 9-bit mode. Note however that should an overrun or error interrupt actually occur, an address character may also reside in the FIFO. In this case, the software driver should examine the contents of the receiver FIFO as well as process the error.

The above facility produces an interrupt for recognizing any 'address' characters. Alternatively, the user can configure 950 core to match the receiver data stream with up to four programmable 9-bit characters and assert a level 5 interrupt after detecting a match. The interrupt occurs when the character is transferred to the FIFO (See below).

**NMR[0]: 9-bit mode enable**

- logic 0 ⇒ 9-bit mode is disabled.
- logic 1 ⇒ 9-bit mode is enabled.

**NMR[1]: Enable interrupt when 9<sup>th</sup> bit is set**

- logic 0 ⇒ Receiver interrupt for detection of an 'address' character (i.e. 9<sup>th</sup> bit set) is disabled.
- logic 1 ⇒ Receiver interrupt for detection of an 'address' character (i.e. 9<sup>th</sup> bit set) is enabled and a level 1 interrupt is asserted.

*Special Character Detection*

While the UART is in both 9-bit mode and Enhanced mode, setting IER[5] will enable detection of up to four 'address' characters. The least significant eight bits of these four programmable characters are stored in special characters 1 to 4 (XON1, XON2, XOFF1 and XOFF2 in 650 mode) registers and the 9<sup>th</sup> bit of these characters are programmed in NMR[5] to NMR[2] respectively.

- NMR[2]: Bit 9 of Special Character 1
- NMR[3]: Bit 9 of Special Character 2
- NMR[4]: Bit 9 of Special Character 3
- NMR[5]: Bit 9 of Special Character 4

**NMR[7:6]: Reserved**

Bits 6 and 7 of NMR are always cleared and reserved for future use.

**6.11.10 Modem Disable Mask 'MDM'**

The MDM register is located at offset 0x0E of the ICR. This register is cleared after a hardware reset to maintain compatibility with 16C550. It allows the user to mask interrupts and control sleep operation due to individual modem lines or the serial input line.

**MDM[0]: Disable delta CTS**

- logic 0 ⇒ Delta CTS is enabled. It can generate a level 4 interrupt when enabled by IER[3]. Delta CTS can wake up the UART when it is asleep under auto-sleep operation.
- logic 1 ⇒ Delta CTS is disabled. It can not generate an interrupt or wake up the UART.

**MDM[1]: Disable delta DSR**

- logic 0 ⇒ Delta DSR is enabled. It can generate a level 4 interrupt when enabled by IER[3]. Delta DSR can wake up the UART when it is asleep under auto-sleep operation.
- logic 1 ⇒ Delta DSR is disabled. It can not generate an interrupt or wake up the UART.

**MDM[2]: Disable Trailing edge RI**

- logic 0 ⇒ Trailing edge RI is enabled. It can generate a level 4 interrupt when enabled by IER[3]. Trailing edge RI can wake up the UART when it is asleep under auto-sleep operation.
- logic 1 ⇒ Trailing edge RI is disabled. It can not generate an interrupt or wake up the UART.

**MDM[3]: Disable delta DCD**

- logic 0 ⇒ Delta DCD is enabled. It can generate a level 4 interrupt when enabled by IER[3]. Delta DCD can wake up the UART when it is asleep under auto-sleep operation.
- logic 1 ⇒ Delta DCD is disabled. It can not generate an interrupt or wake up the UART.

**MDM[7:4]: Reserved**

These bits must be set to '0000'

**6.11.11 Readable FCR 'RFC'**

The RFC register is located at offset 0x0F of the ICR

This read-only register returns the current state of the FCR register (Note that FCR is write-only). This register is included for diagnostic purposes.

**6.11.12 Good-data status register 'GDS'**

The GDS register is located at offset 0x10 of the ICR. Good data status is set when the following conditions are true:

- ISR reads level0 (no interrupt), level2 or 2a (receiver data) or level3 (THR empty) interrupt.
- LSR[7] is clear i.e. no parity error, framing error or break in the FIFO.
- LSR[1] is clear i.e. no overrun error has occurred.

GDS[0]: Good Data Status

GDS[7:1]: Reserved

**6.11.13 DMA Status Register 'DMS'**

The DMS register is located at offset 0x11 of the ICR. This register is unused in the OXCF950 except for test purposes.

**6.11.14 Port Index Register 'PIX'**

The PIX register is located at offset 0x12 of the ICR. This read-only register gives the UART index. For a single channel device such as the OXCF950 this reads '0'.

**6.11.15 Clock Alteration Register 'CKA'**

The CKA register is located at offset 0x13 of the ICR. This register adds additional clock control mainly for isochronous and embedded applications. The register is effectively an enhancement to the CKS register.

This register is cleared to 0x00 after a hardware reset to maintain compatibility with 16C550, but is unaffected by software reset. This allows the user to select a clock mode and then reset the channel to work-around any timing glitches.

**CKA[0]: Invert internal RX Clock**

This allows the sense of the receiver clock to be inverted. The main use for this would be to invert an isochronous

input clock so the falling edge were used for sampling rather than the rising edge.

**CKA[1]: Invert internal TX clock**

This allows the sense of the transmitter clock to be inverted. The main use for this would be to invert an isochronous input clock so the rising edge were used for data output rather than the falling edge.

**CKA[2]: Invert DTR**

This allows the DTR output signal to be inverted, which is most likely to be useful when DTR is selected as being the transmitter clock for isochronous applications.

**6.11.16 Misc Data Register**

The Misc Data Register allows the user to select access to either the local configuration registers or the local bus, when the OXCF950 is operating in Local Bus Mode. When the OXCF950 is operating in Generic mode (8 byte address space), it causes the local configuration registers to overlay the UART registers. It has no effect when the OXCF950 is operating in Normal Mode. When exiting generic mode access to configuration registers, b0 is cleared automatically.

Table 40 describes the MDR register operation.

MDR Bits	Description
7:1	Reserved for future use : '0' must be written to these.
0	Active low Local Bus Enable (Local Bus mode only). Setting this bit to '0' allows access to local bus. Setting this bit to '1' allows access to local configuration registers.

Table 40: MDR operation

## 7 SERIAL EEPROM SPECIFICATION

The OXCF950 can be configured using an optional serial electrically-erasable programmable read only memory (EEPROM). If the EEPROM is not present, the device will remain in its default configuration after reset. Although this may be adequate for some applications, many will benefit from the degree of programmability afforded by this feature. The EEPROM also allows accesses to the integrated UART, which can be useful for default setups.

The EEPROM interface supports a variety of serial EEPROM devices that have a proprietary serial interface known as Microwire™. This interface has four pins which supply the memory device with a clock, a chip-select, and serial data input and output lines. In order to read from such a device, a controller has to output serially a read command and address, then input serially the data. The interface controller has been designed to handle (auto detect) the following list of compatible devices that have a 16-bit data word format but differ in memory size (and hence the number of address bits). NM93C46 (64 WORDS), NM93C56 (128 WORDS), devices with 256 WORDS, 512 WORDS and 1024 WORDS.

The OXCF950 incorporates a controller module which reads data from the serial EEPROM and writes data into the relevant register space. It performs this operation in a sequence which starts immediately after a CF/PCMCIA reset and ends either when the controller finds no EEPROM is present or when it reaches the end of the eeprom data.

Following device configuration, driver software can access the serial EEPROM through four bits in the device-specific Local Configuration Register ESC[4:1]. Software can use this register to manipulate the device pins in order to read and modify the EEPROM contents as desired.

A Windows® based utility to program the EEPROM is available. For further details please contact your local distributor.

Microwire™ is a trade mark of National Semiconductor. For a description of Microwire™, please refer to National Semiconductor data manuals.

### 7.1 EEPROM data Organisation

The serial EEPROM data is divided into 4 zones. The size of each zone is an exact multiple of 16-bit WORDS. Zone 0 is allocated to the header. An EEPROM program must contain a valid header before any further data is interrogated. The EEPROM can be programmed from the CF/PCMCIA Interface.. The general EEPROM data structure is shown in Table 41.

Note the zone information is not stored 0,1,2,3 but as shown in the table (0, 2, 1, 3).

DATA Zone	Size (WORDS)	Description
0	One	Header
2	One or more	Local Configuration registers
1	Two or more	CIS Configuration
3	Multiples of two	Function Access

Table 41: EEPROM Data Format

### 7.2 Zone 0: Header

The zone header identifies the EEPROM program as valid, and is the first value to be read and is at address 0 in the EEPROM. It has the following format:

Bits	Description
15:4	These bits should return 0xB12 to identify a valid program. Once it reads this value from these bits it sets bit [TBD] in the TBD register in the local register.
3	Reserved
2	1 = Zone 1 (CIS Configuration) data exists 0 = Zone 1 does not exist
1	1 = Zone 2 (Local Register Configuration) data exists 0 = Zone 2 does not exist
0	1 = Zone 3 (Function Access) data exists 0 = Zone 3 does not exist

Table 42: Zone 0 format

The programming data for each zone follows the proceeding zone if it exists (again note order is zone 0, 2, 1, 3). For example a header value of 0xB127 indicates that all zones exist, while 0XB123 indicates that only zone 2 and zone 3 exist.

### 7.3 Zone 1: Card Information Structure

This zone allows the user to provide custom tuple information for the Card Information Structure (CIS), overriding the default hard-coded tuple values found in the device. Downloading into this zone programs the internal RAM with the user's tuple data and automatically sets the source of the CIS to be this RAM, and not the hard coded value.

Note: if the CIS is to be modified using the EEPROM, tuple values presented to the host will be those programmed into the RAM. The user must ensure that the RAM contains all the correct tuples for the particular application.

Tuple data bytes are interrogated until the specified number of type data-bytes have been collected in which case the EEPROM moves over to the next zone if it exists, or the EEPROM download terminates if no other zones are present.

The zone contains two areas to download to:

- Attribute memory (RAM address (0 to 127)
- Common memory (RAM address (128 to 255)

Usually all tuple data is held in attribute memory, but some applications may use common memory as well.

The first WORD in this zone describes how many bytes of data are present in each zone. The next words contain the tuple data. The first set of WORDS contain the tuples for the common memory (if present) followed by the tuple WORDS for the attribute memory.

If the tuple data is an odd number of bytes it should be padded at the end with an additional 'FF'.

Byte Number	Description	
	15	8 7 0
1 <sup>st</sup> WORD	Number of tuple bytes in Common Memory (N) Note : Must be a value of multiple of 2	Number of tuple bytes in Attribute Memory (M) Note : Must be a value of multiple of 2
2 <sup>nd</sup> WORD	Attribute Mem.Tuple Byte 1	Attribute Mem.Tuple Byte 0
3 <sup>rd</sup> WORD	Attribute Mem.Tuple Byte 3	Attribute Mem.Tuple Byte 2
(N + 1) th WORD	Attribute Mem.Tuple Byte N-1	Attribute Mem.Tuple Byte N-2
(N + 2) th WORD	Common Mem. Tuple Byte 1	Common Mem. Tuple Byte 0
(N + 3) th WORD	Common Mem. Tuple Byte 3	Common Mem. Tuple Byte 2
(N + M + 1) th WORD	Common Mem. Tuple Byte M-1	Common Mem. Tuple Byte M-2

Table 43: Word format for Zone 1

### 7.4 Zone 2: Local Register Configuration

The Zone 2 region of EEPROM contains the program value of the vendor-specific Local Configuration Registers using one or more configuration WORDs. Registers are selected using a 7-bit byte-offset field. This offset value is the offset from address 8 (allowing addresses 0 to 7 to be reserved for function access).

Bits	Description
15	'0' = There are no more configuration WORDs to follow in Zone 2. Move to next available zone or end EEPROM program if no more zones are enabled in the header. '1' = There is another configuration WORD to follow for the Local Configuration Registers
14:8	Local Register address (in IO space). Valid address range is 8 to 15
7:0	8-bit value of the register to be programmed

Table 44: Word format for Zone 2

### 7.5 Zone 3: Function Access (UART)

Zone 3 allows the UART to be pre-configured, prior to any CF/PCMCIA accesses. This is very useful when the UART needs to run with (typically generic) device drivers and these drivers are not capable of utilising the enhanced features/modes of the UART (e.g. 950 mode) that are required for high performance. By using function access, the UART registers can be accessed (setup) via the EEPROM to customize the UART features before control is handed to the device drivers.

Each 8-bit access is equivalent to accessing the UART function through IO space (addresses 0 to 7), with the exception that a function read access does not return any data (it is discarded). The UART function behaves as though these function accesses via the EEPROM were corresponding CF/PCMCIA access.

Each entry for zone 3 comprises of 2 16-bit words. The format is as shown.

1 <sup>st</sup> WORD (of WORD pair)	
Bits	Description
15	Value = 1
14:12	Reserved (write 0's)
11	0 = Function read access 1 = Function write access
10:8	Reserved (write 0's)
7:0	IO address to access (valid values 0 to 7)

Table 45: Zone 3 (first WORD) format

2 <sup>nd</sup> WORD (of WORD pair)	
Bits	Description
15	'1' = another function access WORD pair to follow '0' = no more function access WORD pairs
14:8	Reserved (write 0's)
7:0	Data to be written to specified addresses. Field is unused for function access READS (set to 0)

Table 46: Zone 3 (second WORD) format

## 8 OPERATING CONDITIONS

Symbol	Parameter	Min.	Max.	Units
V <sub>DD</sub>	DC supply voltage	-0.3	3.8	V
V <sub>IN</sub>	DC input voltage	-0.3	V <sub>DD</sub> + 0.3	V
I <sub>OUT</sub>	DC output current		+/- 10	mA
T <sub>STG</sub>	Storage temperature	-55	125	°C

Table 47: Absolute Maximum Ratings

Symbol	Parameter	Min	Max	Units
V <sub>DD</sub>	DC supply voltage	2.7	3.6	V
T <sub>O</sub>	Operating Temperature range	-40	105	°C

Table 48: Recommended Operating Conditions



## 9 DC ELECTRICAL CHARACTERISTICS

### 9.1 3.0V to 3.6V Operation

Symbol	Parameter	Condition	Min.	Max.	Units
V <sub>DD</sub>	Supply voltage		3.0	3.6	V
V <sub>IH</sub>	Input high voltage	LVTTL 5V tolerant <sup>Note 1</sup> LVTTL LVTTL Schmitt trigger	2.0 2.0 1.8 typical	2.3	V
V <sub>IL</sub>	Input low voltage	LVTTL 5V tolerant <sup>Note 1</sup> LVTTL LVTTL Schmitt trigger	0.5	0.8 0.8 0.9 typical	V
V <sub>H</sub>	Schmitt Hysteresis	LVTTL	0.4		V
I <sub>IH</sub>	Input high leakage current	V <sub>in</sub> = V <sub>DD</sub>	-10	10	μA
I <sub>IL</sub>	Input low leakage current	V <sub>in</sub> = V <sub>SS</sub>	-10	10	μA
V <sub>OH</sub>	Output high voltage	I <sub>OH</sub> = 2 mA <sup>Note2</sup>	2.4		V
V <sub>OL</sub>	Output low voltage	I <sub>OL</sub> = 2 mA <sup>Note2</sup>		0.4	V
I <sub>OZ</sub>	3-state output leakage current		-10	10	μA
I <sub>ST</sub>	Static current <sup>Note3</sup>	V <sub>in</sub> = V <sub>DD</sub> or V <sub>SS</sub>	-	40	μA
I <sub>CC</sub>	Operating supply current in normal mode <sup>Note3</sup>	f <sub>CK</sub> = 1.8432 MHz f <sub>CK</sub> = 8.192 MHz f <sub>CK</sub> = 50.00 MHz	0.9 3.3 10.7	1.1 3.6 11.4	mA
	Operating supply current in sleep mode <sup>Note3</sup>	f <sub>CK</sub> = 1.8432 MHz f <sub>CK</sub> = 8.192 MHz f <sub>CK</sub> = 50.00 MHz	-	0.7 2.6 6.6	mA

Table 49: DC Electrical Characteristics

- Note 1: All input buffers are 5V tolerant LVTTL with the exception of RESET, Z\_CTS, Z\_DSR, Z\_DCD and Z\_RI which are Schmitt triggered LVTTL, and XTLI which is LVTTL but not 5V tolerant.
- Note 2: All output buffers are 4 mA drive capability, with the exception of the EEPROM signals, Z\_IOIS16, Z\_IREQ and the UART output signals which are all 2 mA drive capability.
- Note 3: Divider ratio of 1. These are sample measured figures.

9.2 2.7V – 3.6V Operation

Symbol	Parameter	Condition	Min.	Max.	Units
V <sub>DD</sub>	Supply voltage		2.7	3.6	V
V <sub>IH</sub>	Input high voltage	LVTTL 5V tolerant <sup>Note 1</sup> LVTTL LVTTL Schmitt trigger	1.9 1.9 1.6 typical	2.1	V
V <sub>IL</sub>	Input low voltage	LVTTL 5V tolerant <sup>Note 1</sup> LVTTL LVTTL Schmitt trigger	0.4	0.7 0.7 0.8 typical	V
V <sub>H</sub>	Schmitt Hysteresis	LVTTL	0.3		V
I <sub>IH</sub>	Input high leakage current	V <sub>in</sub> = V <sub>DD</sub>	-10	10	μA
I <sub>IL</sub>	Input low leakage current	V <sub>in</sub> = V <sub>SS</sub>	-10	10	μA
V <sub>OH</sub>	Output high voltage	I <sub>OH</sub> = 2 mA <sup>Note2</sup>	2.1		V
V <sub>OL</sub>	Output low voltage	I <sub>OL</sub> = 2 mA <sup>Note2</sup>		0.4	V
I <sub>OZ</sub>	3-state output leakage current		-10	10	μA
I <sub>ST</sub>	Static current <sup>Note3</sup>	V <sub>in</sub> = V <sub>DD</sub> or V <sub>SS</sub>	-	40	μA
I <sub>CC</sub>	Operating supply current in normal mode <sup>Note3</sup>	f <sub>CK</sub> = 1.8432 MHz f <sub>CK</sub> = 8.192 MHz f <sub>CK</sub> = 50.00 MHz	0.9 3.3 10.7	1.1 3.6 11.4	mA
	Operating supply current in sleep mode <sup>Note3</sup>	f <sub>CK</sub> = 1.8432 MHz f <sub>CK</sub> = 8.192 MHz f <sub>CK</sub> = 50.00 MHz	-	0.7 2.6 6.6	mA

Table 50: DC Electrical Characteristics

- Note 1: All input buffers are 5V tolerant LVTTL with the exception of RESET, Z\_CTS,Z\_DSR, Z\_DCD and Z\_RI which are Schmitt triggered LVTTL, and XTLL which is LVTTL but not 5V tolerant.
- Note 2: All output buffers are 4 mA drive capability, with the exception of the EEPROM signals, Z\_IOIS16, Z\_IREQ and the UART output signals which are all 2 mA drive capability.
- Note 3: Divider ratio of 1. These are sample measured figures.

10 TIMING WAVEFORMS / AC CHARACTERISTICS

10.1 Memory Access

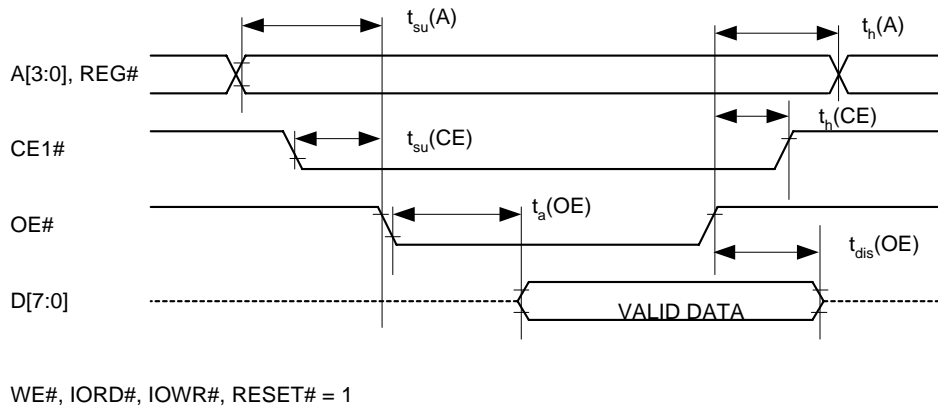

Figure 8: Attribute/Common Memory Read Timing

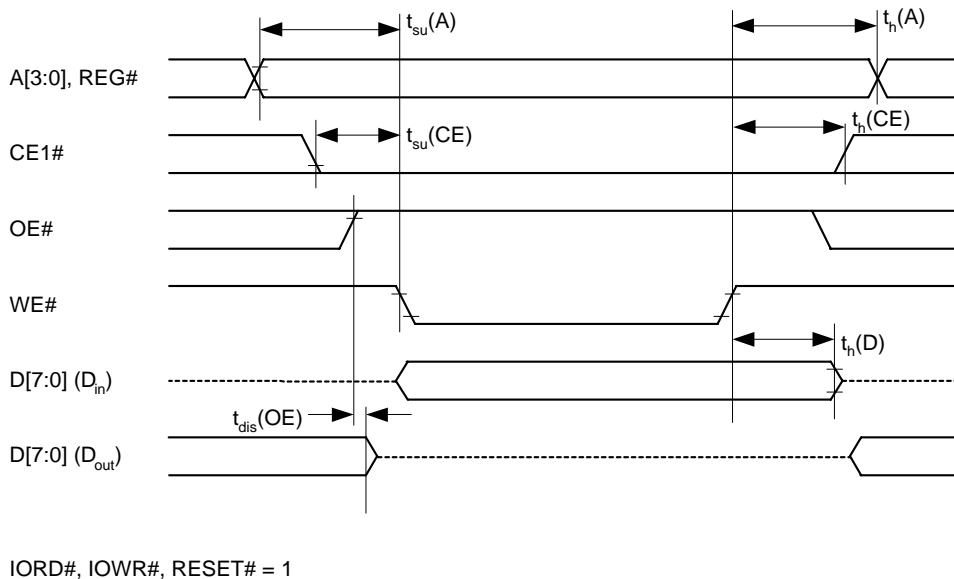
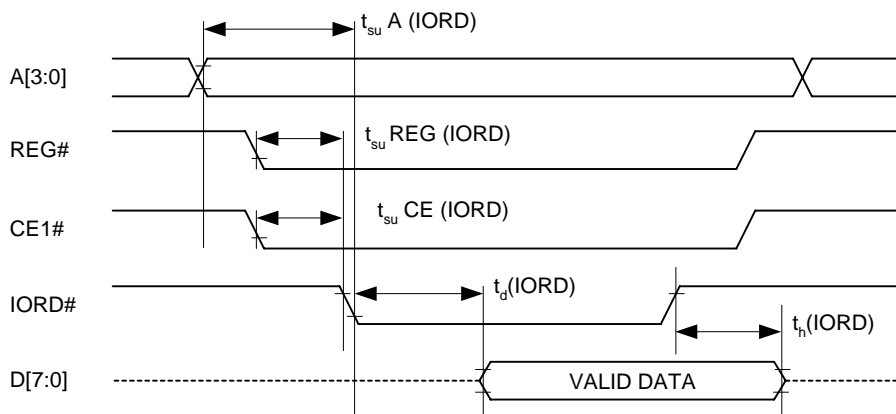

Figure 9: Attribute/Common Memory write timing

Symbol	Read Access		Write Access	
	Min (ns)	Max (ns)	Min (ns)	Max (ns)
$t_{su}(A)$	1		1	
$t_{su}(CE)$	1		1	
$t_a(OE)$		35		
$t_{dis}(OE)$		15		15
$t_h(D)$			4	
$t_h(A)$	0		0	
$t_h(CE)$	0		0	

Table 51: Memory Access Timing Specification

10.2 I/O Access



OE#, WE#, IOWR#, RESET# = 1

Figure 10: I/O read timing

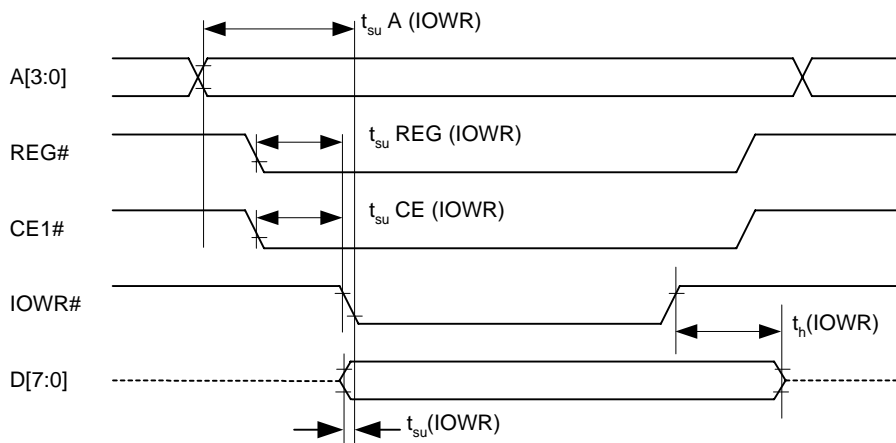

OE#, WE#, IORD#, RESET# = 1

Figure 11: I/O write timing

Symbol	Read Access		Write Access	
	Min (ns)	Max (ns)	Min (ns)	Max (ns)
t <sub>su</sub> A (IORD)	TBD			
t <sub>su</sub> REG (IORD)	TBD			
t <sub>su</sub> CE (IORD)	TBD			
t <sub>d</sub> (IORD)		36		
t <sub>h</sub> (IORD)	TBD			
t <sub>su</sub> A (IOWR)			TBD	
t <sub>su</sub> REG (IOWR)			TBD	
t <sub>su</sub> CE (IOWR)			TBD	
t <sub>su</sub> (IOWR)			TBD	
t <sub>h</sub> (IOWR)			TBD	

Table 52: I/O Access Timing Specification

11 PACKAGE INFORMATION

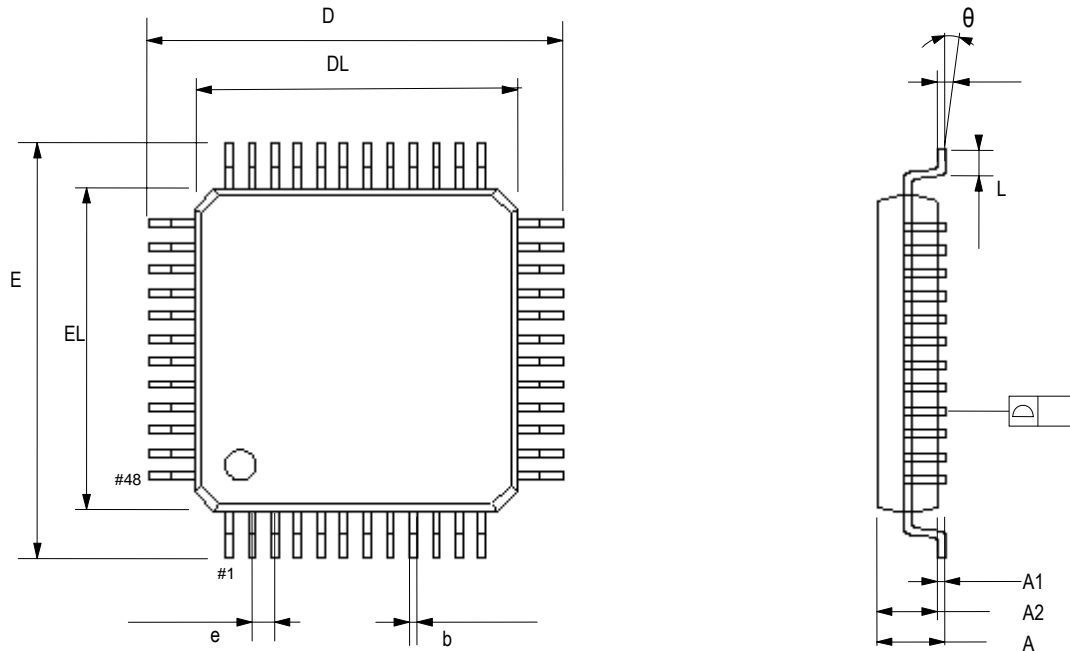

Figure 12: TQFP Device packaging

Dimension	Min	Nom	Max
D		9.00 BSC	
DL		7.00 BSC	
E		9.00 BSC	
EL		7.00 BSC	
A			1.20
A1	0.05		0.15
A2	0.95	1.00	1.05
b	0.17	0.22	0.27
e		0.50	
L	0.45	0.60	0.75
$\theta$	0.0°		7.0°

Table 53 TQFP package dimensions

NOTE: All dimensions in millimetres. Angles in degrees.

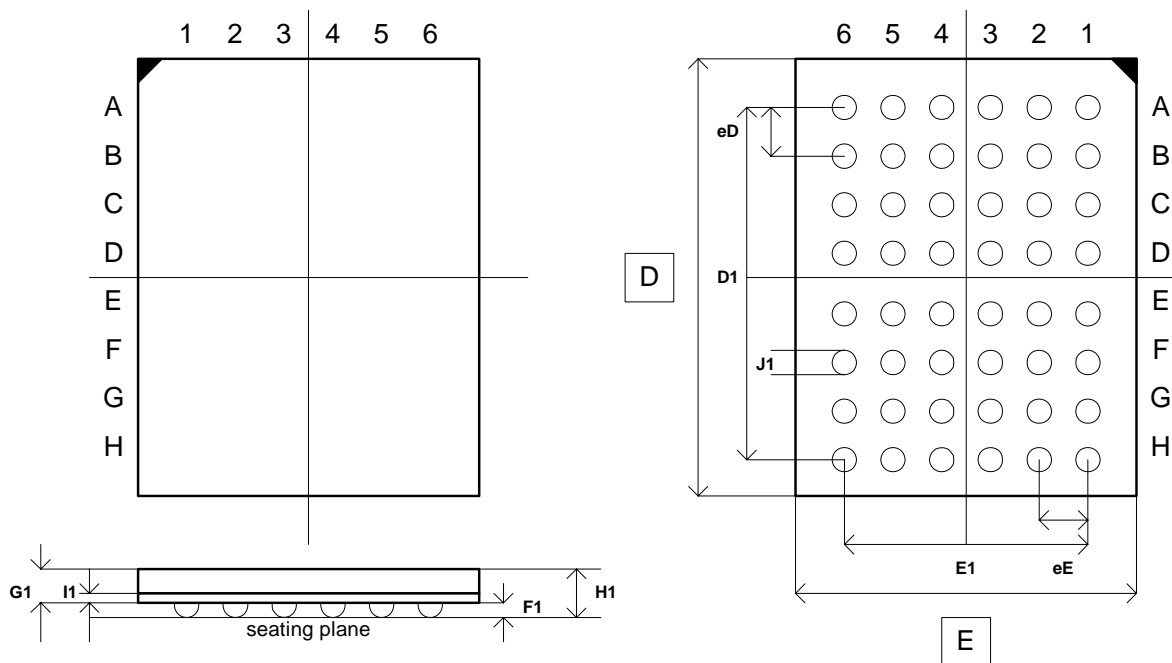

Figure 13: TFBGA Device packaging

Dimension	Min	Nom	Max
D1		5.25	
E1		3.75	
ED		0.75	
EE		0.75	
D	6.95	7.00	7.05
E	6.95	7.00	7.05
H1			1.20
F1	0.20		0.30
G1	0.48	0.53	0.58
I1	0.31	0.36	0.41
J		0.30	

Table 54: TFBGA Package Dimensions

Table 53 : TFBGA Package Dimensions

NOTE: All dimensions in millimetres. Angles in degrees.

## 12 ORDERING INFORMATION

---

OXCF950-TQ - B  
Revision  
Package Type – 48 TQFP

OXCF950-TB - B  
Revision  
Package Type – 48 TFBGA

OXCF950-TQ B G  
Green (ROHS Compliant)  
Revision  
Package Type – 48 TQFP

OXCF950-TB B G  
Green (ROHS Compliant)  
Revision  
Package Type – 48 TFBGA



*NOTES*

---

This page has been intentionally left blank

## CONTACT DETAILS

---

Oxford Semiconductor, Inc.  
25 Milton Park  
Abingdon  
Oxfordshire  
OX14 4SH  
United Kingdom

*Telephone:* +44 (0)1235 824900  
*Fax:* +44 (0)1235 821141  
*Sales e-mail:* [sales@oxsemi.com](mailto:sales@oxsemi.com)  
*Web site:* <http://www.oxsemi.com>

## DISCLAIMER

---

Oxford Semiconductor believes the information contained in this document to be accurate and reliable. However, it is subject to change without notice. No responsibility is assumed by Oxford Semiconductor for its use, nor for infringement of patents or other rights of third parties. No part of this publication may be reproduced, or transmitted in any form or by any means without the prior consent of Oxford Semiconductor, Inc. Oxford Semiconductor terms and conditions of sale apply at all times.